

**Produced by:  
R-moto GmbH  
Jagerweg 2  
9400 Wolfsberg  
Austria**

**Engine User Manual**

Engine No.: \_\_\_\_\_

Date: \_\_\_\_\_

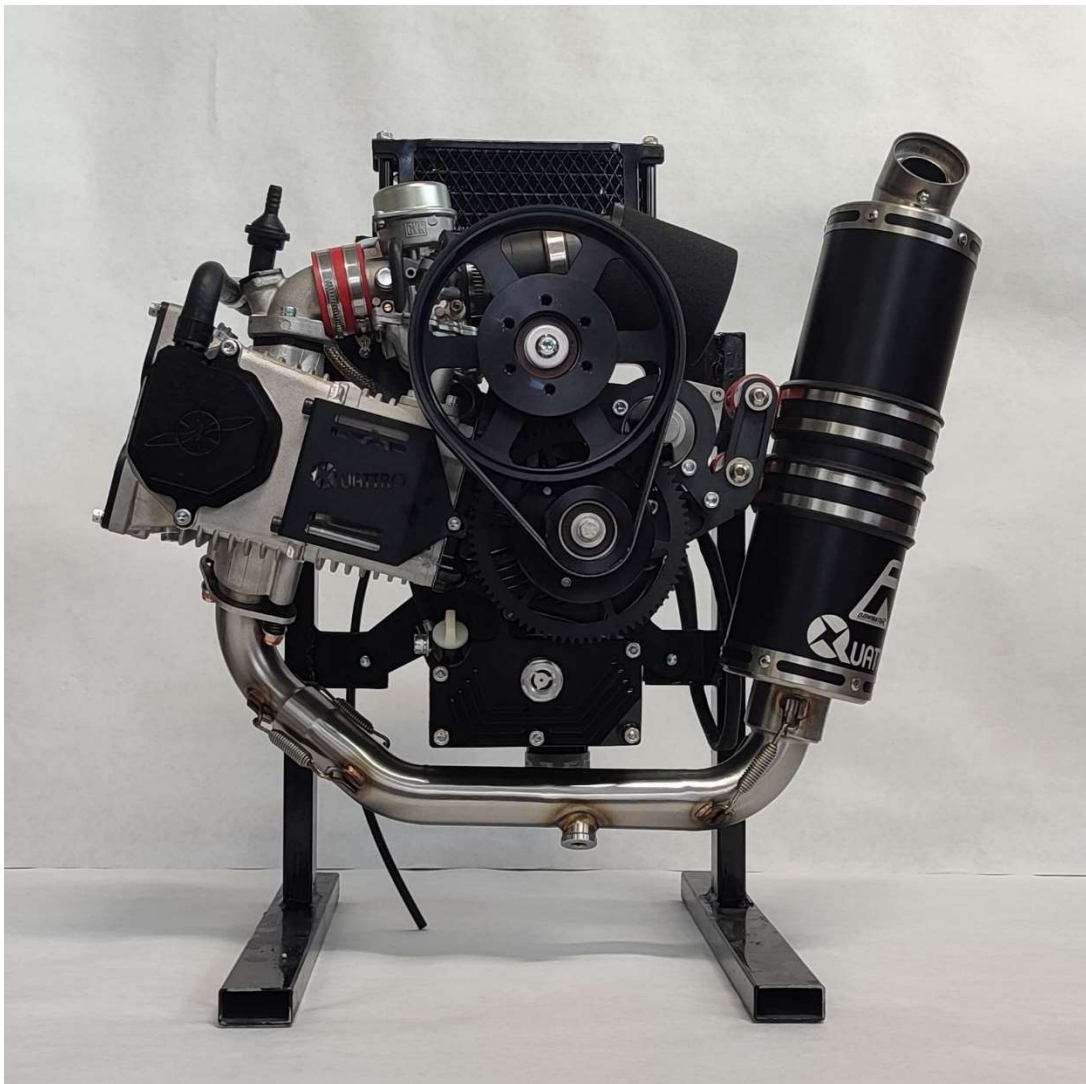



---

## Welcome

---

Congratulation to your purchase of the new 4 stroke EOS QUATTRO ENGINE. The engine will provide many hours of reliability, low noise, and flying time accompanied by very low fuel consumption.

Please thoroughly read this owner's manual before proceeding to mount or start your new engine. This engine was developed having most professional engineers involved. It has been thoroughly tested by our test pilots. All the engine components are made of high-quality materials.

We have taken all the necessary steps to develop this manual as accurate and instructive as possible. All data and procedures in this content are correct at the time of print. However, we EOS ENGINE by R-Moto GmbH, Austria, keep the right to make specification and detail changes to any part of our equipment, components and manufacturing processes including this manual without recourse.

For the latest version of this manual, please see the download section of our website at: [www.eos-engine.com](http://www.eos-engine.com).

This manual covers the component parts of the engine, the mounting, run-in, starting/stopping procedures and offers guidelines on maintenance and proper up-keep of your EOS QUATTRO ENGINE.

This manual is **NOT** a substitute for training.

We strongly advise that you look for professional training and obtain a valid license or a certification to fly.

---

## Contents

---

Page	Description
2	Welcome, Contents
3	Supplied parts, Engine Configuration, Engine Description
4	Applications, Engine Specifications
5	Engine Mounting Schematic
6-8	Wiring Diagram (Engine + Electric Starter), Two-pin relay, Ground contact, Wiring Installation
9	Fuel Supply System, Installation Notes
10	Installation Notes, Installation Oil-cooler
11	Adjustments – Carburetor Idle Speed, Exhaust Spring Tension
12	Pre-Start Checks, Operation Notes
13	Running-In, Starting
14	Service Schedule, Storage Instructions
15	Maintenance Procedures – Oil & Filter Change
16	Maintenance Procedures – Drive Belt Tensioning
17	Maintenance Procedures – Valve Clearance Adjustment, Starter Motor Sprocket Adjustment
18-19	Screw Torque Specifications, Warranty, Disclaimer
20	Notes



---

### Supplied Parts

---

The EOS QUATTRO ENGINE is supplied with the following components: Exhaust system, carburetor, air filter, oil cooler including hoses, wiring, CDI, ignition coil and voltage regulator for battery and electric starter.

We do not allow the use of other manufacturers` fuel pumps. Warranty claims will be denied if a non-EOS-certified fuel pump is used!

The EOS QUATTRO electric start or dual start option is delivered with following parts: starter, starter gear sprocket, starter bracket, relay, and a voltage regulator.

---

### Engine Configuration

---

The EOS QUATTRO ENGINE can be supplied either with a manual starter, an electric starter or a dual starter.

The purchase of a clutch system with 2800 RPM engagement or 2000 RPM engagement is possible if required. Our engine can be used either for a push or a pull propeller.

We supply a 95W generator and oil cooler.

---

### Engine Description

---

EOS QUATTRO is our 2nd generation of the EOS 4-stroke engine series. It provides smooth and progressive power, having low noise levels and a very low fuel consumption.

EOS QUATTRO engine is a lightweight single cylinder 4-stroke 4 Valve engine including a decompression start system. The decompression system releases 70% of the compression during the starting sequence. This enables the engine to be easily started. Once the engine starts, the decompression system automatically disengages.

EOS QUATTRO is a 2-piece full CNC machined alloy crankcase engine. The engine has 276cc displacement, using 4 valves operated by a chain driven overhead camshaft. The oil system is driven by an oil pump and supplies constant oil pressure regardless of the oil temperature or RPM.

Our EOS QUATTRO alloy cylinder is high end coated for increased wear resistance and it is precisely balanced. The crankshaft design includes oversize bearings for long durable use.

Our crankshaft is held by two main bearings. The engines` main drive is an eccentric shaft that delivers power via a Poly-V 16 ribs belt.

CDI ignition (capacitive discharge) uses an integrated variable advance ignition curve.

We have chosen float type carburetor (CVK30 JAPAN) with a high flow foam air filter and high-quality rubber duct.

EOS QUATTRO ENGINE uses an oil cooling system that consists of an oil pump, hoses, and an oil cooler.

**WARNING:** The ignition CDI unit should NEVER be mounted directly on the engine.

The oil filter is permanent and easily removable. A clear and transparent glass oil level window allows the pilot to check the oil level.

Our exhaust manifolds are made of stainless steel for long durability. The manifold is fixed with 2 pressure springs to the cylinder to enhance the best flexibility possible. Our silencers alloy outer shell and inner stainless-steel material enhances a long-time use, it is mounted with 2 stainless clamps and 2 silicon rubber mounts to provide a flexible mounted exhaust system.

Every EOS QUATTRO ENGINE has been put through pre-delivery running tests in the factory. After testing the engine, it is thoroughly cleaned. **THE ENGINE WILL BE DELIVERED WITHOUT THE ENGINE OIL! PLEASE ADD THE ENGINE OIL PRIOR TO RUNNING THE ENGINE!**



---

### Applications

---

Recommended applications for EOS-ENGINE QUATTRO engines are:

- Paramotor
- Paratrikes
- Hangglider trikes
- Small single seat aircrafts
- Hovercraft

**PLEASE DON'T USE EOS QUATTRO ENGINE FOR ACROBATIC FLIGHTS!**

---

### Quattro Engine Specifications

---

Manufacturer	EOS ENGINE by R-moto GmbH, Austria
Type	Single cylinder 4 stroke, oil cooled, 4 valve
Displacement	276cc
Bore/Stroke	73x66mm
Crankshaft	2 Bearing C3
Piston	Forged Racing alloy
Oil System	Wet sump with pressure pump and oil filter
Fuel system	CVK float bowl carburetor with acceleration pump
PRSU/Reduction	3.0:1 reduction with poly-V drive 16 ribs
Prop Mounting	6 x 50mm M6 screws
Exhaust	Flexible stainless-steel manifold, alloy stainless Silencer with DP Killer
Starter	Manual pull start, Electric start, or Dual start
Ignition System	CDI
Oil Capacity	450cc
Oil Type	Fully Synthetic 10W50 or 10W60 4 stroke motorcycle oil (Spec – JASO – MA2 –API –SL)
Mountings	4 x M8 Silicon shock mounts (red)
Spark Plug type	NGK CR8E
Spark Plug Gap	0.60mm
Air filter	High flow foam filter
Oil Filter	Grid filter, no need to change
Drive belt tension	4-6mm Deflection at mid span point with 14Kg force or Frequency App, 380Hz
Valve clearances	0.10mm for inlet and 0,12mm exhaust valves
Fuel Type	95 or higher (Ron) Octane unleaded fuel
Engine Weight	Starting from 17,6 kg – depending on available options
Starter Motor Type	Pre-engaged
Battery (not included)	12v 3ah minimum – Lead Acid or Lead Gel type or lithium
Generator	95W
Power Output at Crankshaft	30,2hp @ 8100 RPM
Thrust Output (static)	>80Kg with 1.30m propeller, measured on the trust test bench w/o cage, at 400m @ 20 degree
Max Power RPM	Limited to 3 minutes
Max Continuous RPM	7200 RPM
Oil Temp	Max 150 ° C Min 55°C
Cyl Head Temp	Max 210 ° C Min 70°C
Consumption	Depending on glider size and take-off weight. 2,2 to 2,8 liter per hour

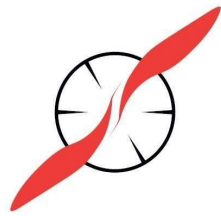

**EOS**  
— ENGINE —

Engine Mounting Schematic / Dimensions

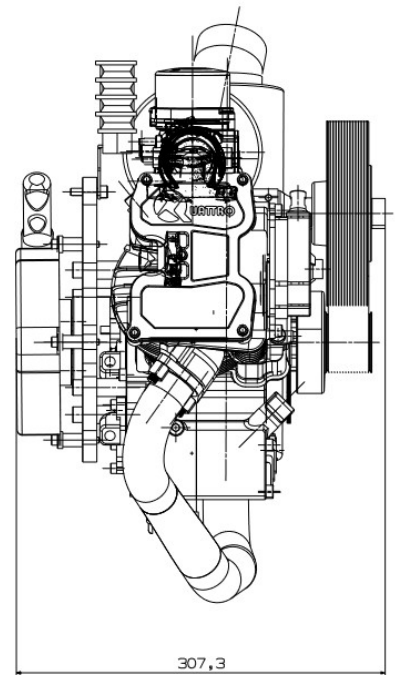
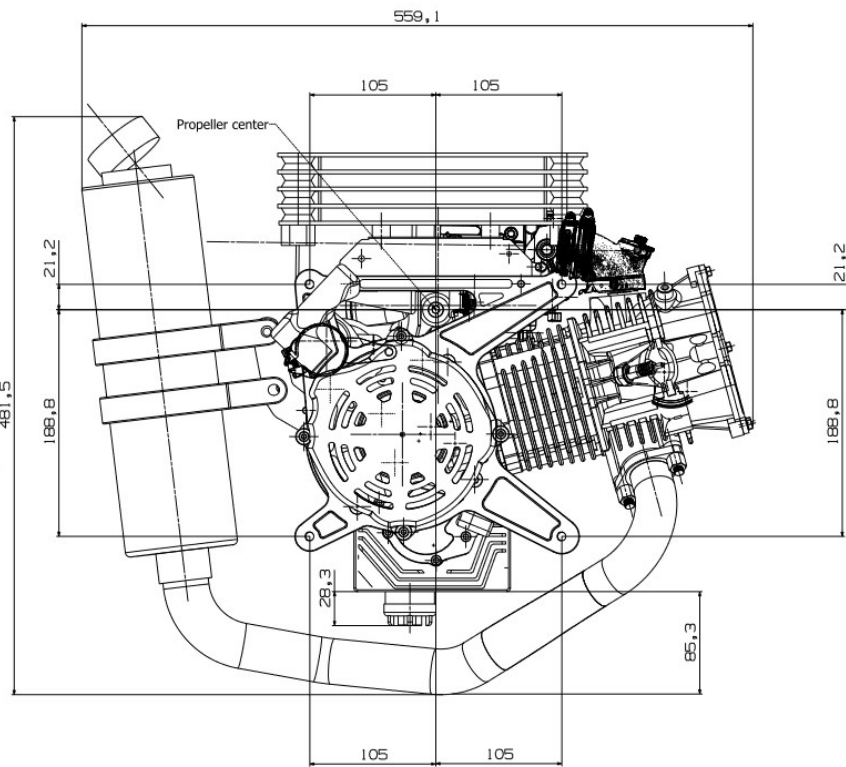
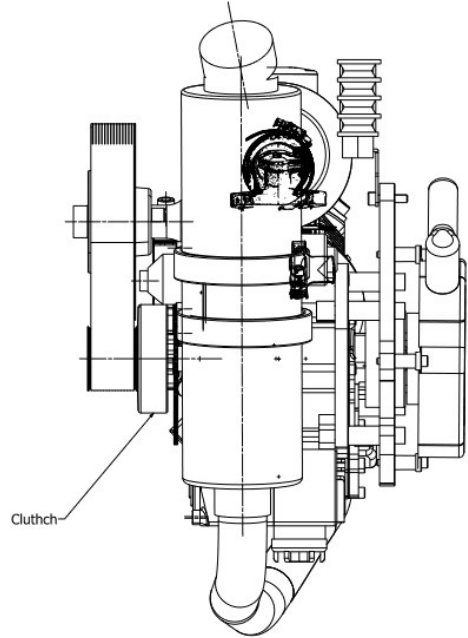
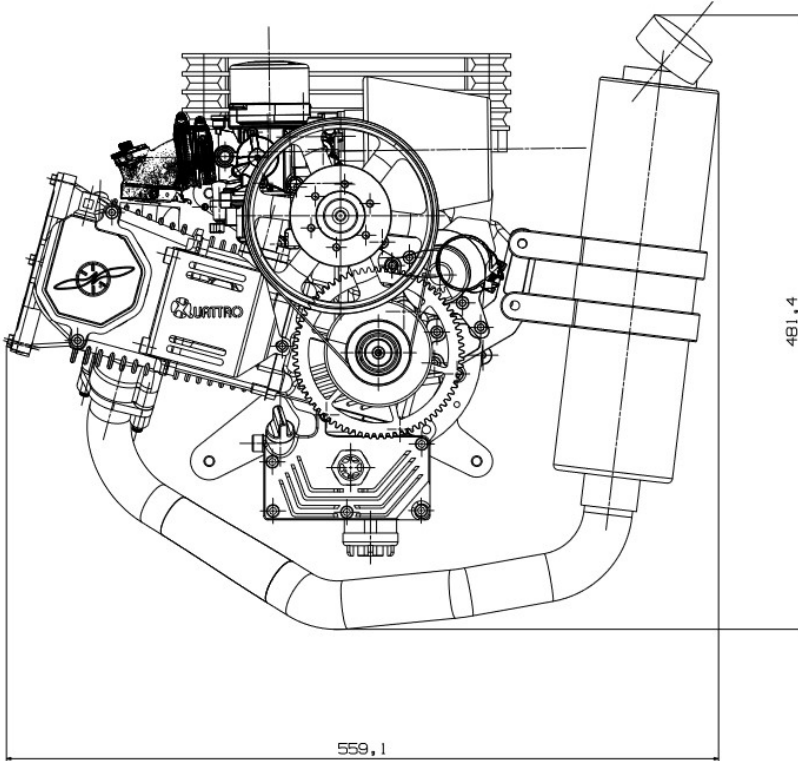

Wiring Diagram Engine

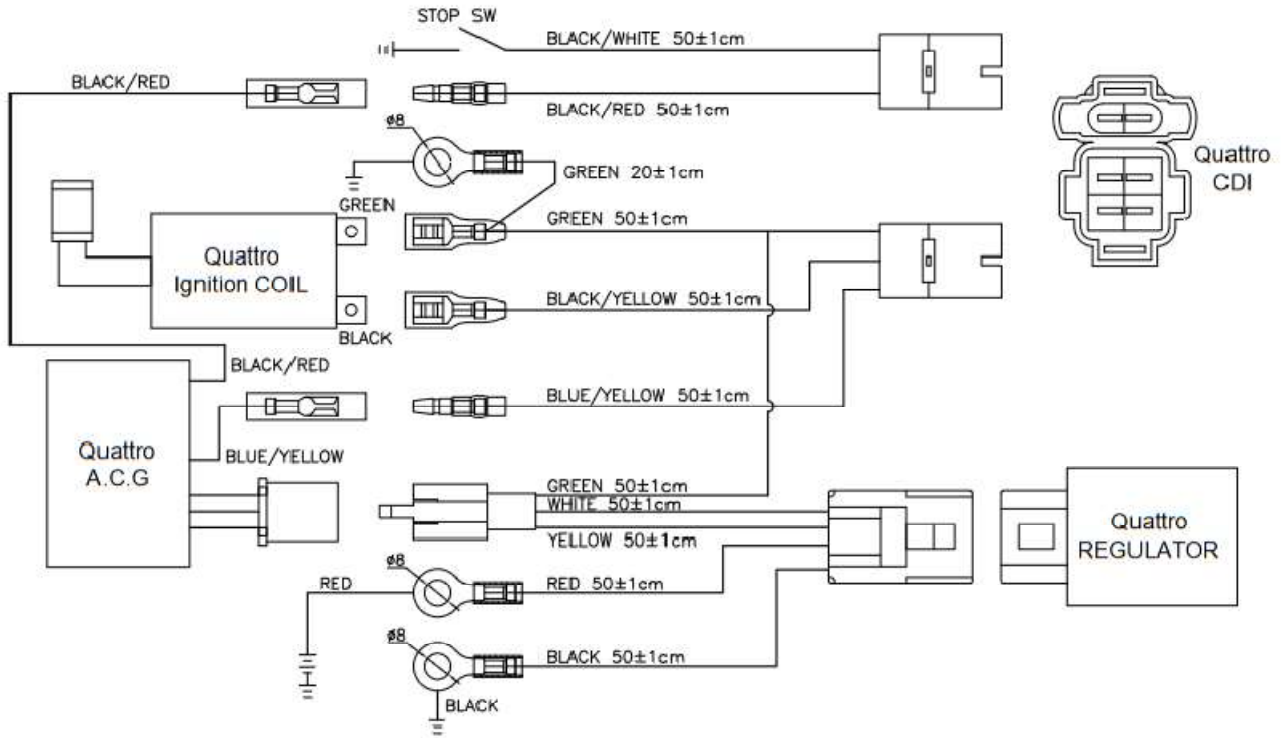

**Important:** Please install the rectifier only when using a lead battery (for charging). You also need a connection from battery minus to engine ground!

Wiring Diagram Electric starter

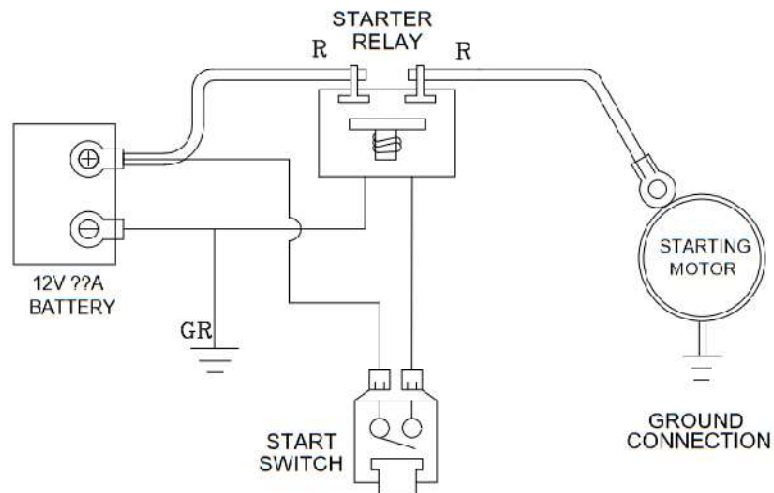

Quattro Electric Start System Diagram

---

Two-pin electric start relay

---

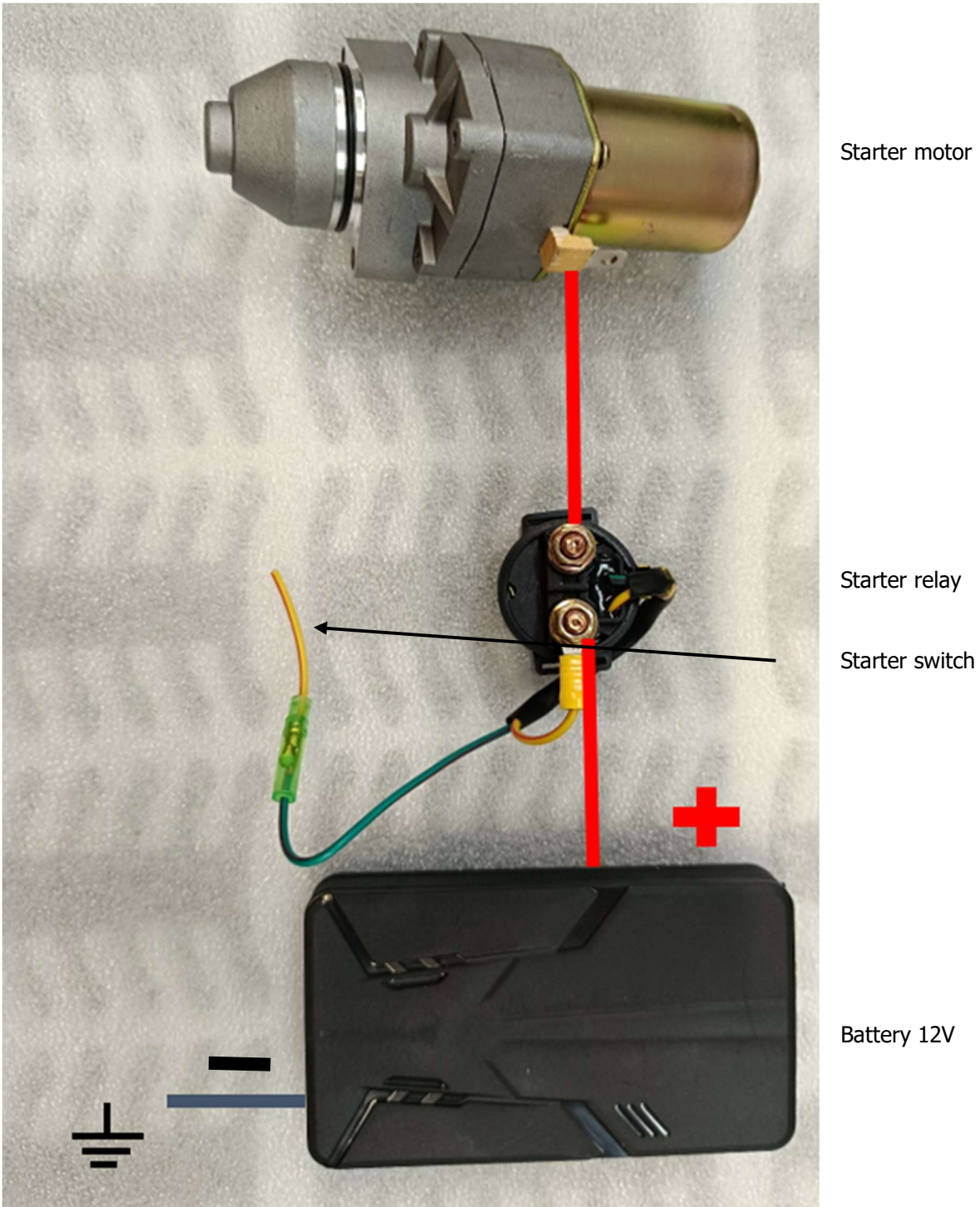

Connect starter switch and battery minus ( - ) to ground – use 6mm<sup>2</sup> cable!  
The startermotor ground cable must be connected directly to the battery.

---

Ground contact

---

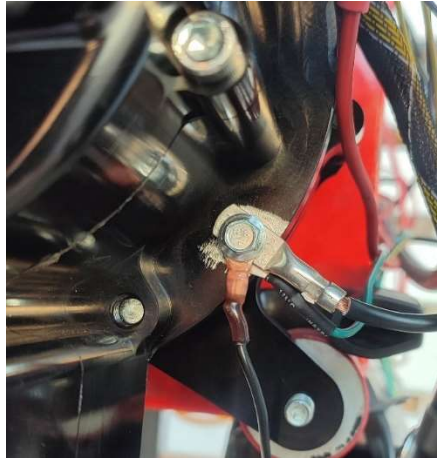

**IMPORTANT!**

Please connect all ground wirings to the engine ground contact. The green cable is for ignition!

If the green ground cable is not fixed at this point, the engine will not start correctly and can cause wrong ignition timing. We recommend using min 6mm<sup>2</sup> starter cable! Best option is 8mm<sup>2</sup>.

---

Wiring installation

---

If no battery is used, you don't have to install the rectifier.

The wiring is delivered like on the left picture – the left part is the wiring and the rectifier for charging the battery and the right part is for the ignition system.

If you don't use a battery you can disconnect the white cable including the rectifier, like on the right picture.

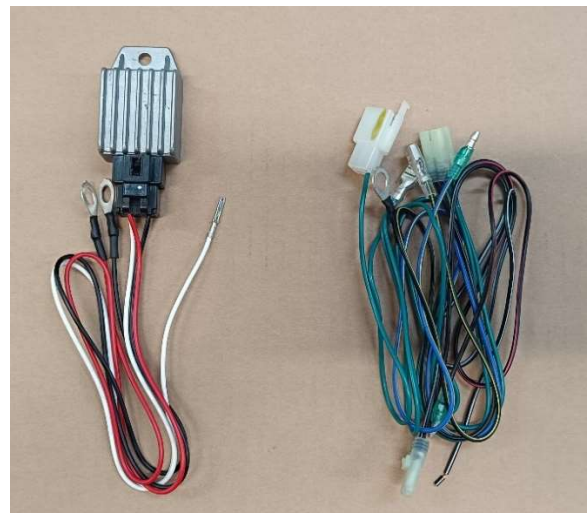
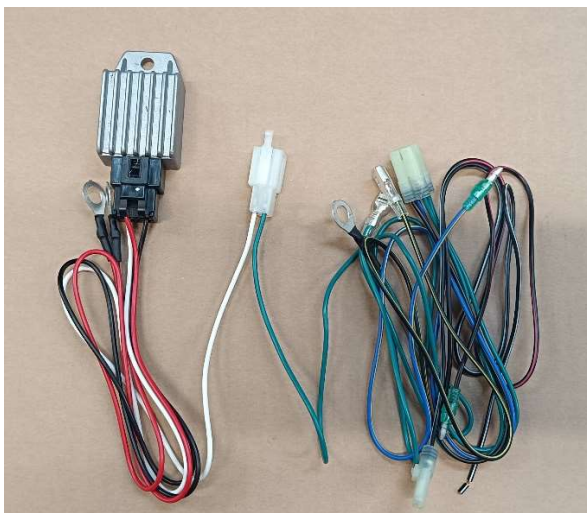



---

Fuel Supply System

---

**Important note!**

EOS QUATTRO ENGINE uses a membrane fuel pump for fuel supply.

**WARNING:** only the fuel pump system from EOS works flawlessly. It's unique bypass system enables the correct fuel flow and pressure.

**NOTE:** Check the bypass reduction (alloy reduction, red circle) every 100 hours. The bypass channel should be clean and without cracks. If the bypass channel is clogged, it will cause the carburetor to overflow. The vacuum hose should not exceed 250mm length measured from the carburetor to the fuel pump (see picture below). The engine uses a membrane fuel pump for fuel supply. **WARNING: USE ONLY THE FUEL PUMP SUPPLIED BY EOS.** The fuel pump has a unique bypass system that enables the correct fuel flow and pressure.

**Never use alternative fuel pumps.**

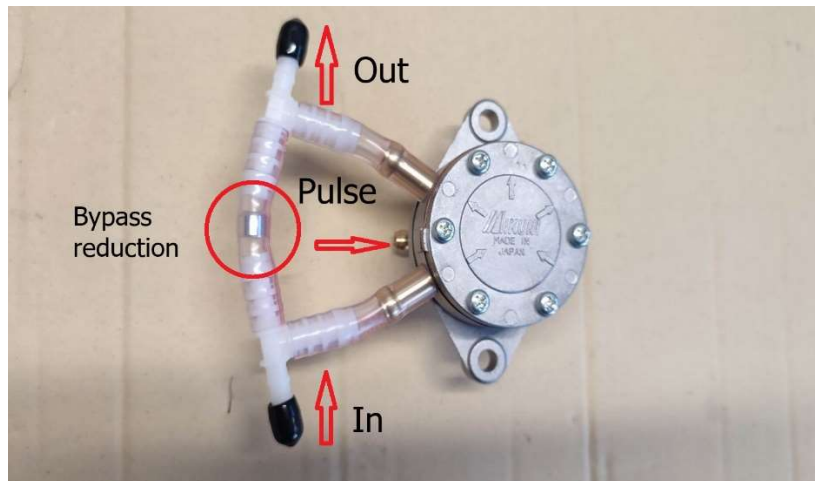

---

Installation Notes

---

EOS QUATTRO ENGINE is provided with a black and white cable exiting the CDI. The connection of these cables to the kill switch enables to stop the engine. EOS QUATTRO ENGINE is supplied with an additional wiring loom and voltage regulator.

The carburetor has a vent tube fixed to the bowl and a return pipe, which must be mounted to the fuel tank. The routing of this return pipe must be arranged so that there is a constant 'downfall' to the fuel tank with no possibility of fuel 'puddling' in the line. Modification of the fuel breather and return lines in any way will cause carburation problems. This return line can be used for a fuel tank ventilation at the same time.

**Engine Ventilation:**

EOS QUATTRO ENGINE is supplied with a breather hose (black hose) and PCV valve to reduce crank case pressure being connected to the engine ventilation cover outlet. You can connect a tube to the PCV valve located on the top of the black hose, to blow the air away from the engine.

**Fuel line attachment:**

The fuel line must be attached to the fuel primer pump between the fuel tank and Quattro vacuum fuel pump. We recommend a 'primer' bulb of some sort upstream of the pump to enable manual filling of the carburetor prior to starting. Please use fuel lines with 6mm inner diameter.



#### Choke:

The CVK carburetor has a choke installed, when your EOS QUATTRO ENGINE is cold, open the choke and start the engine. If the ambient engine temperature is around 0 degrees Celsius, you can also press and release the throttle for 3 times to get the engine to start.

After the engine has been running for 30 seconds, close the choke.

**WARNING:** The propeller will start to spin by using the choke!

#### Propeller:

We test all engines using E-props QUATTRO Propeller sizes 120cm to 150cm.

The propeller must be fastened according to the propeller manufacturer torque advise (15nm).

#### Throttle cable:

EOS QUATTRO ENGINES are not supplied with a throttle assembly. Throttles can be purchased separately. Once the throttle is installed, make sure that the carburetor lever can fully open and close. The engine kill button on the throttle should be easy to reach during takeoff and while airborne.

#### Oil cooling:

Always keep your oil cooler clean.

**Attention:** the oil cooler will be very hot after the engine runs! There must be sufficient clearance for the oil cooler to enable air flow. A minimum space of 100mm between the harness and the oil cooler is required.

#### Exhaust:

Always ensure a minimum distance of 100mm from the exhaust system to your frame or fuel tank. The manifold can reach very high temperatures.

**WARNING:** do not remove the DB killer on the silencer outlet, it will lean the mixture and damage your engine.

---

### Installation Oil-cooler

---

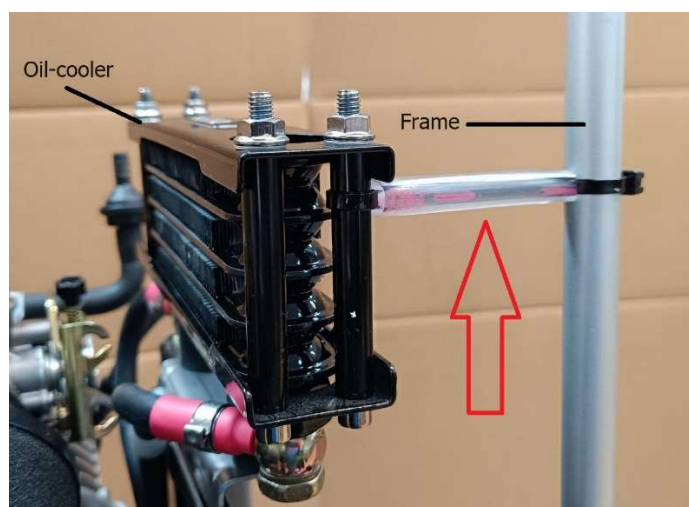

Use a simple cable tie covered with a silicon-fuel-tube to fix the oil-cooler to the frame to avoid strong vibrations.

---

### Adjustments - Carburetor Idle Speed

---

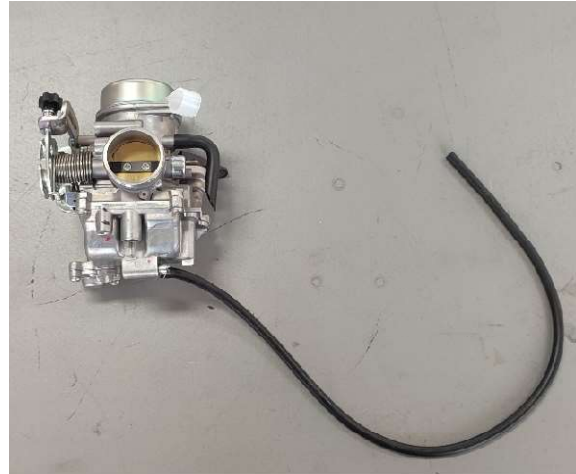
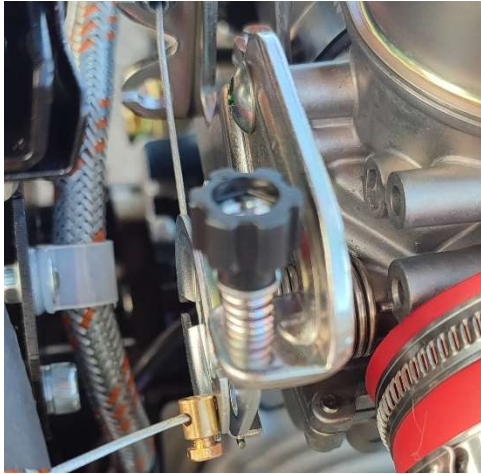

The Idle speed is adjusted by turning the small screw at the side of the throttle quadrant as shown in the picture.

The idle speed should be 1900- 2100 RPM with the clutch – 2800 RPM version,  
and 2100 to 2300 RPM with the clutch – 2000 RPM version.

The end of the black tube from the float chamber of the carburetor must be connected to the fuel tank – see the second picture.

---

### Adjustments - Exhaust Spring Tension

---



EOS QUATTRO ENGINE exhaust has two M8-bolt fasteners at the cylinder. This allows expansion/contraction of the manifold. The springs are factory pre-set to provide an optimum flexibility of the manifold. In case you need to adjust the spring tension, you should leave a 0,4 – 0,6mm gap between each coil of the spring as shown in the picture above.



---

### Pre-Start Checks - Warnings

---

The Engine Oil Level - With engine placed on a flat surface, the oil level should be between the halfway (min) and top (max) mark of the glass oil window.

The Fuel System - Ensure that you have enough fuel for the planned flight.

The Exhaust System - Ensure that exhaust system is secure, check swivel springs at both ends of the manifold and the condition of the silencer clamps. DO NOT open M8-copper-nuts, these are factory pre-set to provide optimum clamping force, allowing sufficient expansion/contraction of the exhaust assembly (There must be 0,4-0,8 mm gap between each coil of the springs – see page 8).

The Air Filter and the Carburetor - Ensure that the air filter is clean, and not damaged. Make sure that the filter is tightened securely. Check that the securing clamps are fastened! Check the condition of the rubber duct, located between the carburetor and the inlet manifold. It is important that both clamps are tight and placed correctly.

The Spark Plug cable and cap – Check that the spark plug cap is fully pushed and firmly seated onto the plug. It is not necessary to remove/check spark plug before each flight. Repeated unnecessary removal of the spark plug cap will cause it to become loose.

The Oil cooler - Ensure there is no debris on the oil cooler, so that the air can flow through it easily. Make sure that there is no leaking.

The Throttle Assembly - Visually check for full throttle travel on the carburetor and ensure throttle opens and closes fully and smoothly.

The Reduction Drive and the Propeller - Check that the propeller is free from cracks and chips. The mounting bolts should be tightened to 8nm.

The Drive Belt – Check the Poly-V drive belt for cracks, wear, and tension.



**Propellers can be very dangerous, DO NOT start engine where there is any chance of the propeller coming into contact with the operator, any other person, or object.**

---

### Operation Notes

---



**Prior to starting your EOS QUATTRO ENGINE, you should always follow the full pre-start check list as shown on page 10.**

Ensure propeller cannot contact anything or anyone. Else (In the case of a paramotor, machine must either be

1. Securely strapped to a pilot or
2. Securely fixed to proprietary test platform

DO NOT start your paramotor unless one of these 2 rules is obeyed.



---

### Running-In

---

All EOS QUATTRO ENGINES have been fully tested prior to customer release, but you must adhere to the following procedure to ensure no damage is caused to your engine in the first few critical running hours. After the first 3 running hours change oil and clean oil filter. At the 10-hour mark, you must change the oil once again, clean the oil filter, and check the engine valve clearance. The procedure is shown on page 12 of this manual. After the 10-hour service, follow the regular maintenance schedule.

After the break-in period (first 10 hours), full power can be used for take-off (1 minute max). Once airborne, power should be reduced to 7000 rpm or less. Varying the engine RPM during this period is recommended. Starting the motor on the ground is strongly discouraged.

---

### Starting

---

Use your manual choke on the CVK carburetor to start your cold EOS QUATTRO ENGINE. The accelerator pump can also be used instead of pushing the throttle mechanism 4-6 times.

Please pay attention when you open your choke, the engine RPM will be higher at choke operation and the propeller will be spinning!

Don't press the throttle with the engine off – this will cause the carburetor to flood.

#### Starting – Cold Start:

- A) Ensure the carburetor is full of fuel by squeezing the primer bulb.
- B) Make sure that the throttle is fully closed.
- C) Open the choke or pump the throttle 4-6 times, temperature depended.
- D) Keep the throttle on released.
- E) Use electric or pull starter to start the engine.
- F) Keep the engine in the fast idle for 30 – 60 seconds.
- G) Kill the motor to check the kill button.

If the ambient temperature is too cold, you will need to continue by opening the choke and pumping the throttle 3 times.

#### Starting – Hot Start:

- A) Keep the throttle on idle or slightly open approx. 5%
- B) Use the electric starter or the pull starter to start engine.



---

Service Schedule

---

Make sure to perform the following service schedule to keep your engine in a perfect running condition – **Failure to carry out the necessary action at the selected frequency may cause poor running or more serious problems that may affect warranty.**

FREQUENCY	ACTION	Date, Signature
Before flight and after each use	Check Oil Level	
	Visually check fuel connections and oil connections	
	Check fixing and rubber mounts	
	Check that throttle returns to fully closed position and full throttle can be obtained, do not push the throttle to often! The engine will be flooded	
	Check propeller leading edge for damage	
	Check all securing nuts/bolt/engine mounts	
After initial (3hours) 10 hours	Replace engine oil & clean oil filter	
	Check valve clearance and oil hose screws torque	
Every 25 hours	Replace engine oil & clean oil filter	
	Check drive belt tension & wear	
	Check valve clearance	
Every 50 hours	Replace air filter and spark plug. Use EOS QUATTRO ENGINE filter!!	
	Grease exhaust connection with copper grease	
Every 100 hours or every year	Replace engine ventilation valve	
	Replace engine mounts, exhaust mounts & oil cooler mounts	
	Replace drive belt	
	Replace fuel filter	
Every 500 hours	Contact EOS ENGINE regarding 'Zero Hour' overhaul or time extension	

---

Storage Instructions

---

If you plan not to use your engine for a longer time (3+ months) we recommend following steps prior to storage of your EOS QUATTRO ENGINE:

- 1) Loosen drive belt
- 2) Remove and drain fuel tank
- 3) Drain carburetor float bowl - Using the drain screw squeeze primer bulb and evacuate all the fuel from the system and then re-tighten screws, otherwise let your EOS Quattro engine run at idle speed until the engine comes to a stop.

Returning EOS QUATTRO ENGINE to service after longer storage period:

- 1) Change the engine oil and clean the oil filter.
- 2) Refuel.
- 3) Re-tension drive belt and check wear.
- 4) Thoroughly follow pre-flight checks prior to starting your engine.

---

Maintenance Procedures – Oil & Filter Change

---

Please note that your EOS QUATTRO ENGINE must be up to normal operating temperature before draining oil.

- 1) The engine should be in an upright position when changing the oil.
- 2) Remove the oil drain plug with a 17mm socket and remove the oil filter.
- 3) Drain all used oil into a suitable container.
- 4) Clean the oil filter using a carburetor or a brake cleaner.
- 5) First, reinstall the filter and the spring.
- 6) Next, install the oil drain plug.
- 7) Tighten oil drain plug with a 17mm socket (do not overtighten). Recommended torque is 35 Nm.
- 8) Carefully fill with fully synthetic 4 stroke motorcycle oil (see Page 2 for recommended oil types) until the oil reaches the middle of the oil level window.
- 9) Run the engine then recheck oil level and fill up as necessary.

2)

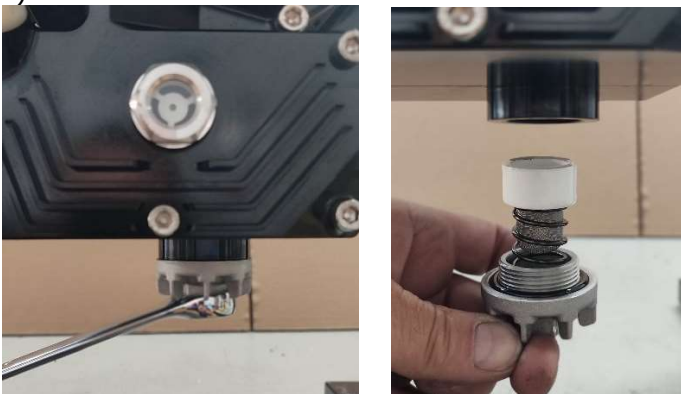

7)

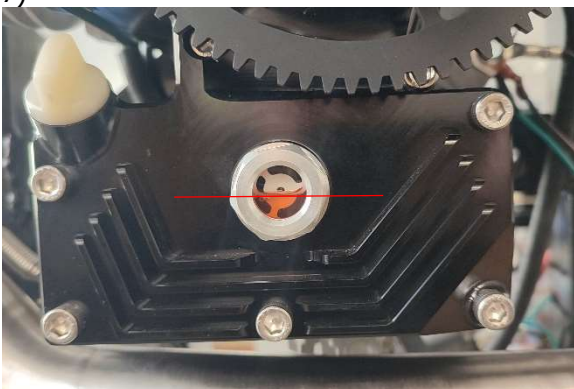

Ensure that the oil filter and the spring fit correctly. Incorrect fitting of the filter will result in severe engine damage.

---

## Maintenance Procedures – Drive Belt Tensioning

---

The ideal drive belt tension is required to prevent slippage. Some slipping (slight chirping noise) at idle speed is quite normal when your engine is adapted with a direct drive. We recommend an optimum belt deflection of 4-6mm (as shown in picture below)

The belt will be pre-tensioned at the factory and must be checked at 3-hour service interval.

The drive belt adjustment should be checked before every flight.

The drive belt can be adjusted by loosening the two M6 bolts at the top of the reduction pylon, and the M8 bolt on the backside. Turning the eccentric drive belt adjuster, with a 23 mm wrench, in clockwise rotation, will tighten the belt, anti-clockwise rotation will loosen the belt. After adjustment re-tighten the bolts (M6 12nm, M8 17nm) and test the belt deflection.

Do not over-tighten the belt – This may cause bearing failure and reduction of available thrust.

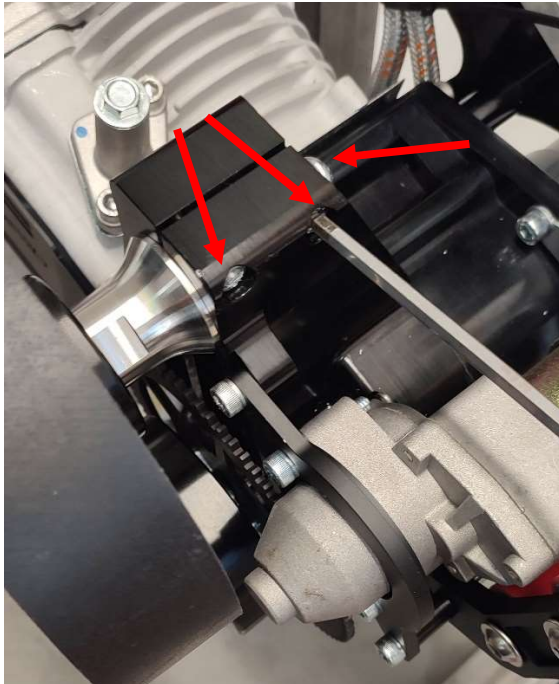



---

### Maintenance Procedures - Valve Clearance Adjustment

---

Remove the valve cover and the adjustment cover. Rotate the engine until inlet valve (nearest the top of the engine) is fully closed and the cam lobe is 180° from the cam follower. Using a suitable feeler gauge, inserted between the valve top and the cam follower adjusting screw. Check and/or adjust by loosening the 8 mm lock nut (see specifications on page 4 for valve clearances).

The same procedure is used on the exhaust valve (nearest the exhaust). However, be aware of the easy start actuator positioned on the exhaust cam base circle. Make sure the cam follower is clear of this to get a correct measurement.

After adjustment ensure both lock nuts are tightened (6nm) and re-fit cam cover (M6 12nm) and adjustment cover.

Remove any excess oil from the cylinder head.

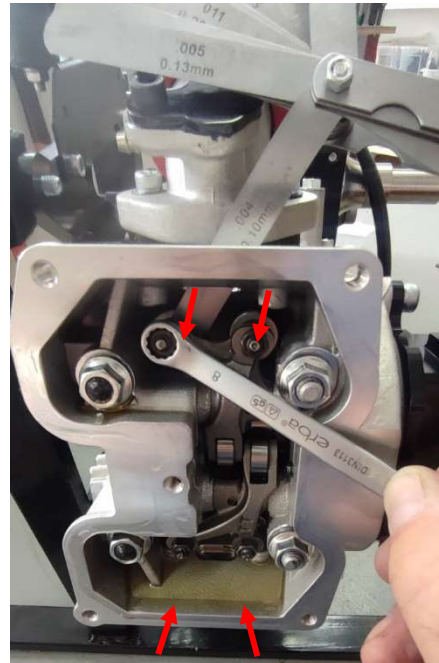

---

### Starter Motor Sprocket Adjustment

---

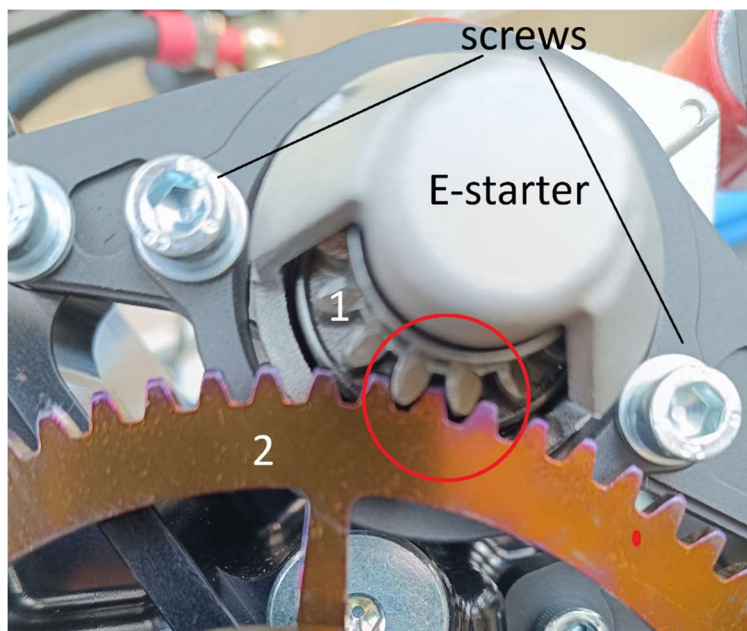

By loosen the screws you can move the starter motor up and down a little bit to adjust it correctly to the starter sprocket (2). For fixation we recommend using blue Loctite, tighten with 16 nm.

The gear play (distance) between starter motor gear (1) and starter sprocket gear (2) should be 0,2 to 0,3 mm (see the red circle)



---

Screw Torque Specifications

---

Screw	Dimension	Torque	Loctite blue
Cylinderhead cam-cover	M 6	12 nm	no
Cylinderhead nut	M 8	24 nm	no
Ventilaton cover	M 6	14 nm	yes
Intake manifold	M 6	14 nm	no
Clutch fix screw	M 6	17 nm	yes
Propeller shaft	M 8	17 nm	yes
	M 6	12 nm	yes
E-Starter	M 6	16 nm	yes
Flywheel	M 14	40 nm	yes
Oil cooler bracket	M 6	14 nm	yes
Exhaust support	M 6	16 nm	yes
Oil pump cover	M 4	7 nm	no
	M 5	10 nm	no
Oil hose screw	M 10	25 nm	yes
	M 12	30 nm	yes
Crankcase screws	M 6	14 nm	no
Engine support	M 8	25 nm	yes

---

Warranty

---

EOS QUATTRO ENGINE offers a 12-month limited parts warranty on all engine components for the purchaser of origin. All warranty claims are return-to-base and can only be carried out by EOS ENGINE by R-moto GmbH, Austria. EOS ENGINE cannot be held responsible for the payment of any delivery/freight charges, including customs duties or taxes. A service history must be assured and provided.

**Warranty claims will not be accepted in the following cases:**

- Engine has not been installed by professional aircraft staff
- Damage caused by immersion in water or damage caused through improper use.
- Damage caused by failure to carry out proper PRE-FLIGHT CHECKS
- Damage caused by neglecting the SERVICE SCHEDULE
- Damage caused by physical dropping, falling or shocks to the paramotor or engine +
- Damage caused by starting engine without a propeller properly fitted.
- Damage caused by starting engine with incorrect propeller type.
- Damage caused by incorrect adjustment of drive belt tension.
- Damage caused by incorrect adjustment of valve clearances.
- Damage caused by using incorrect fuel or oil type, or grade damage caused by lack of engine oil, or incorrect fluid level.
- Damage caused by removing the DB Killer

**Any modification to the engine design, without prior written approval from EOS QUATTRO ENGINE, will void the manufacturer's warranty.**



---

Disclaimer

---

***DANGER***

Engine outs can result in emergency landings. Such landings can lead to serious bodily injuries or death.

Never fly an aircraft equipped with this engine at locations, airspeeds, altitudes, or other circumstances from which a successful no-power landing cannot be made. Aircraft equipped with this engine should only fly in proper VFR conditions.

Paramotors and trikes or small ultralight aircrafts are not certified or licensed as aircrafts. It is the responsibility of the owner/pilot to use their engine in accordance with the rules and regulations set out by the governing body in their designated country or territory. EOS ENGINE by R-moto GmbH, Austria, will not accept any claims for damages or death caused by misuse of any product manufactured or used by them on their products.

***WARNING***

This is not a certified aircraft engine. It has not received any safety or durability testing and conforms to no aircraft standards. It is for use in experimental, uncertified aircraft and vehicles only in which an engine failure will not compromise safety issues. The user assumes all risks of use and acknowledges that there is a possibility of sudden engine-outs.

This manual is for operational guidance on the EOS QUATTRO ENGINE only. Use of this engine is entirely at your own risk – never fly if you are aware of any issues with your equipment, yourself, weather, or unhealthy conditions of any sort.

No part of this manual may be reproduced or distributed in any form or by any means without the prior written approval of EOS ENGINE by R-moto GmbH, Austria.

