

**Produced by:
R-moto GmbH
Jagerweg 2
9400 Wolfsberg
Austria**

Engine User Manual

Engine No.: _____

Date: _____

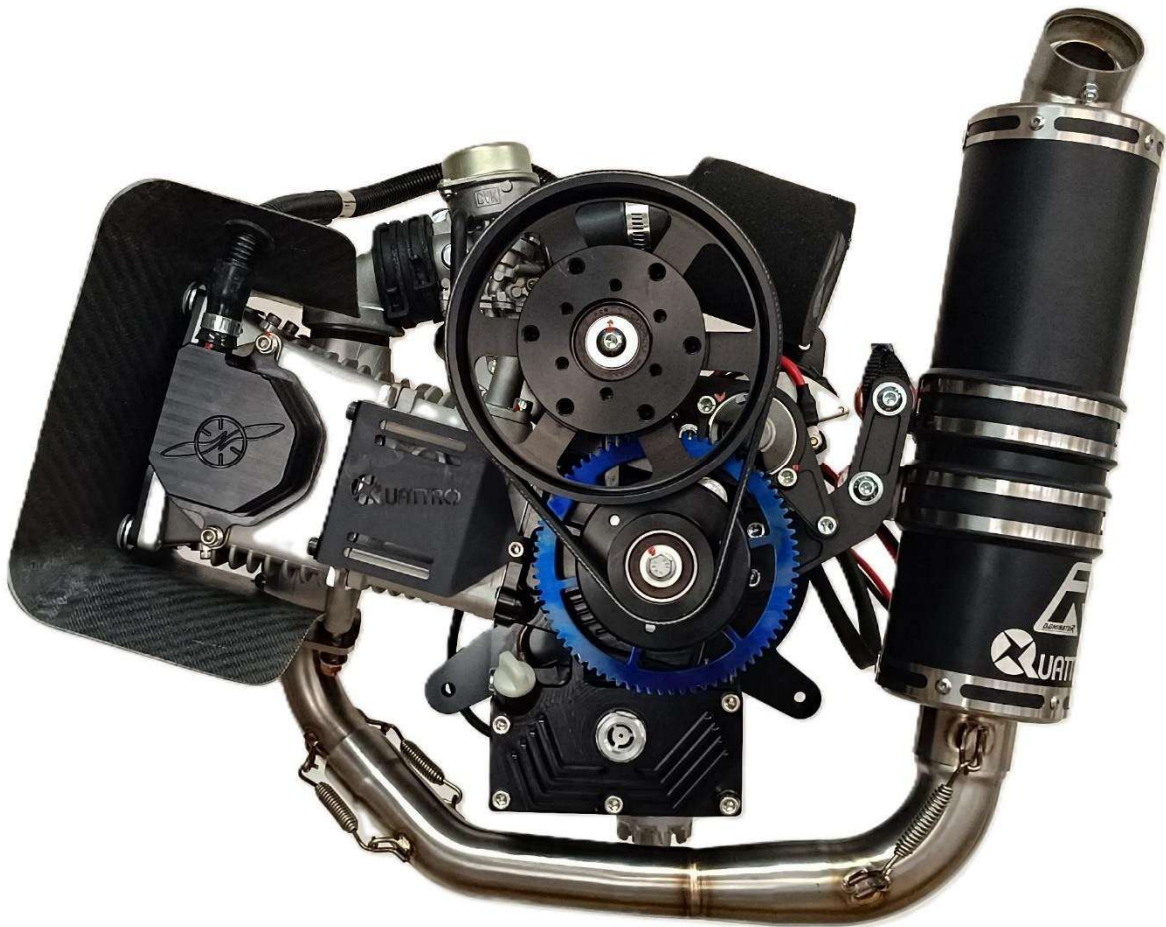



Welcome

Congratulations on your purchase of the EOS Quattro four-stroke engine. This engine is designed to deliver exceptional reliability, minimal noise, and extended flight time, all while maintaining remarkably low fuel consumption.

Prior to mounting or operating your new engine, it is imperative that operators thoroughly review this owner's manual. The EOS Quattro engine has been engineered using high-quality materials and has undergone rigorous testing by our experienced test pilots.

We have made every effort to ensure that this manual is comprehensive and accurate. All information and procedures contained herein are correct as of the date of release. However, we, EOS ENGINE by R-Moto GmbH, Austria, reserve the right to implement changes to specifications, components, and manufacturing processes, including updates to this manual.

For the most current version of this manual, please visit the download section of our website at: www.eos-engine.com.

This manual encompasses the various components of the engine, as well as detailed instructions on mounting, break-in, and starting/stopping procedures. Additionally, it provides essential guidelines for maintenance and proper upkeep of your EOS QUATTRO ENGINE.

Please note that this manual is not a substitute for formal training.

We strongly recommend that you pursue professional training and obtain a valid license or certification prior to operating the engine.



Contents

Welcome.....	2
Contents	3
Supplied Parts	4
Engine Configuration	4
Engine Description	4
Applications	5
Quattro Engine Specifications	6
Engine Mounting Schematic / Dimensions.....	7
Electrical System	9
Fuel Supply System.....	12
Installation Notes.....	13
Installation Cooling shroud	16
Propeller	16
Adjustments - Carburetor Idle Speed	17
Adjustments - Exhaust Spring Tension	17
Pre-Start Checks - Warnings	18
Operation Notes	18
Breaking-In.....	19
Starting	19
Service Schedule	20
Storage Instructions	20
Maintenance Procedures.....	21
Oil & Filter Change	21
Drive Belt Tensioning.....	22
Valve Clearance Adjustment	23
Starter Motor Sprocket Adjustment	23
Screw Torque Specifications	24
Warranty.....	24
Disclaimer	25
Notes.....	26



Supplied Parts

The EOS QUATTRO ENGINE comes equipped with several essential components, including the exhaust system, carburetor, air filter, cooling shroud, wiring, CDI, ignition coil, and a voltage regulator for both the battery and electric starter.

Please note that the use of fuel pumps from other manufacturers is strictly prohibited. Any warranty claims will be rejected if a non-EOS-certified fuel pump is utilized.

The EOS QUATTRO offers an electric start or dual start option, which includes the following parts: starter, starter gear sprocket, starter bracket, relay, and a voltage regulator.

Engine Configuration

The EOS QUATTRO ENGINE can be supplied either with a manual starter, an electric starter, or a dual starter. The purchase of a clutch system with 2800 RPM engagement or 2000 RPM engagement is possible if required. Our engine can be used either for a push or a pull propeller. We supply a 95W generator, an oil cooler, and a cylinder cooling shroud.

Engine Description

The EOS QUATTRO represents the second generation of the EOS 4-stroke engine series, designed to deliver smooth and progressive power while maintaining low noise levels and exceptional fuel efficiency.

This engine is a lightweight, single-cylinder, 4-stroke unit featuring a 4-valve configuration and an innovative decompression start system. This system effectively releases 70% of the compression during the starting sequence, facilitating easy engine starts. Once the engine is operational, the decompression system automatically disengages.

Constructed with a 2-piece, full CNC machined alloy crankcase, the EOS QUATTRO boasts a displacement of 276cc and utilizes 4 valves operated by a chain-driven overhead camshaft. The oil system is powered by an oil pump that ensures consistent oil pressure, irrespective of oil temperature or RPM.

The alloy cylinder of the EOS QUATTRO is coated for enhanced wear resistance and is meticulously balanced. The crankshaft design incorporates oversized bearings to ensure long-lasting durability. The crankshaft is supported by two main bearings, and the engine's primary drive is facilitated by an eccentric shaft that transmits power through a Poly-V 16-rib belt.

The CDI ignition system (capacitive discharge) features an integrated variable advance ignition curve for optimal performance.

We have selected a float-type carburetor (CVK30 JAPAN) equipped with a high-flow foam air filter and high-quality rubber duct. This carburetor includes an accelerator pump, which assists in priming the engine for standard starts and guarantees progressive power delivery during rapid acceleration.

The EOS QUATTRO engine features air/oil cooling system consisting of an oil pump and a cylinder air-cooling shroud. An oil cooler can be added as an option. The cooling shroud is particularly recommended for paramotor applications. If the engine tends to run hotter under certain conditions, the installation of an oil cooler is recommended.

****WARNING:**** The ignition CDI unit must never be mounted directly onto the engine.



The oil filter is designed to be permanent and easily removable, while a clear glass oil level window allows for convenient monitoring of the oil level.

The exhaust manifold is constructed from stainless steel to ensure long-term durability. The manifold is secured to the cylinder with two pressure springs to provide optimal flexibility. The silencer features an alloy outer shell and an inner stainless-steel material, enhancing longevity. It is mounted using two stainless clamps and two silicone rubber mounts to create a flexible exhaust system.

Each EOS QUATTRO ENGINE undergoes rigorous pre-delivery running tests at the factory. Following testing, the engine is thoroughly cleaned. ****IMPORTANT:**** The engine will be delivered without engine oil; it is imperative that engine oil is added prior to operation.

Applications

Recommended applications for EOS-ENGINE QUATTRO engines are:

- Paramotor
- Paratrikes
- Hang-glider trikes
- Small single seat aircraft

EOS QUATTRO ENGINE IS NOT APPROVED FOR ACROBATIC FLIGHTS! THIS WILL RESULT IN ENGINE OIL SCAPING FROM THE CRANKCASE BREATHER.



Quattro Engine Specifications

Manufacturer	EOS ENGINE by R-moto GmbH, Austria
Type	Single cylinder 4 stroke, oil cooler or VT cooling shroud, 4 valve
Displacement	276cc
Bore/Stroke	73x66mm
Crankshaft	2 Bearing C3
Piston	Forged Racing alloy
Oil System	Wet sump with pressure pump and oil filter
Fuel system	CVK float bowl carburetor with accelerator pump
PRSU/Reduction	3.0:1 reduction with poly-V drive 16 rips
Prop Mounting	6 x 50mm M6 screws and 6 x 75mm M8 screws
Exhaust	Flexible stainless-steel manifold, alloy stainless Silencer with DB Killer
Starter	Manual pull start, Electric start, or Dual start
Ignition System	CDI
Oil Capacity	450cc + 80cc when using an oil cooler
Oil Type	Fully Synthetic 10W50 or 10W60 4 stroke motorcycle oil (Spec – JASO – MA2 –API –SL)
Mountings	4 x M8 Silicon shock mounts (red)
Spark Plug type	NGK CR8E
Spark Plug Gap	0.60mm
Air filter	High flow foam filter
Oil Filter	Grid filter, no need to change
Drive belt tension	4-6mm Deflection at mid span point with 14Kg force or Frequency App, 380Hz
Valve clearances	0.10mm for inlet and 0,12mm exhaust valves
Fuel Type	95 or higher (Ron) Octane unleaded fuel
Engine Weight	Starting from 16,9 kg – depending on available options
Starter Motor Type	Pre-engaged
Battery (not included)	12v 3Ah minimum – Lead Acid or Lead Gel type or lithium
Generator	95W
Power Output at Crankshaft	30,6hp @ 8150 RPM
Thrust Output (static)	>80Kg with 1.30m propeller, measured on the trust test bench w/o cage, at 400m @ 20 degree
Max Power RPM	Limited to 3 minutes
Max Continuous RPM	7200 RPM
Oil Temp	Max 140 ° C Min 55°C
Cyl Head Temp	Max 190 ° C Min 70°C
Consumption	Depending on glider size and take-off weight. 2,2 to 2,8 liter per hour

Engine Mounting Schematic / Dimensions

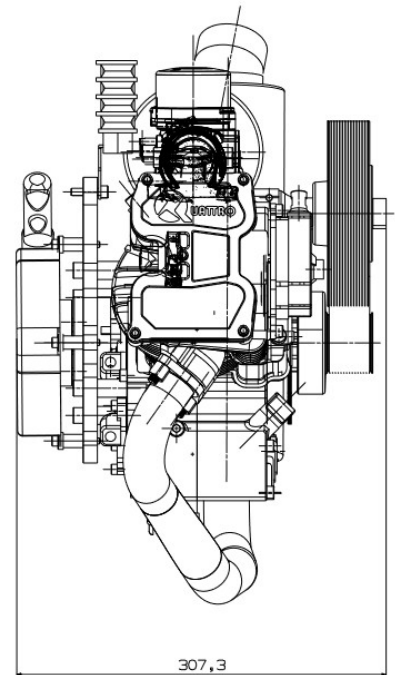
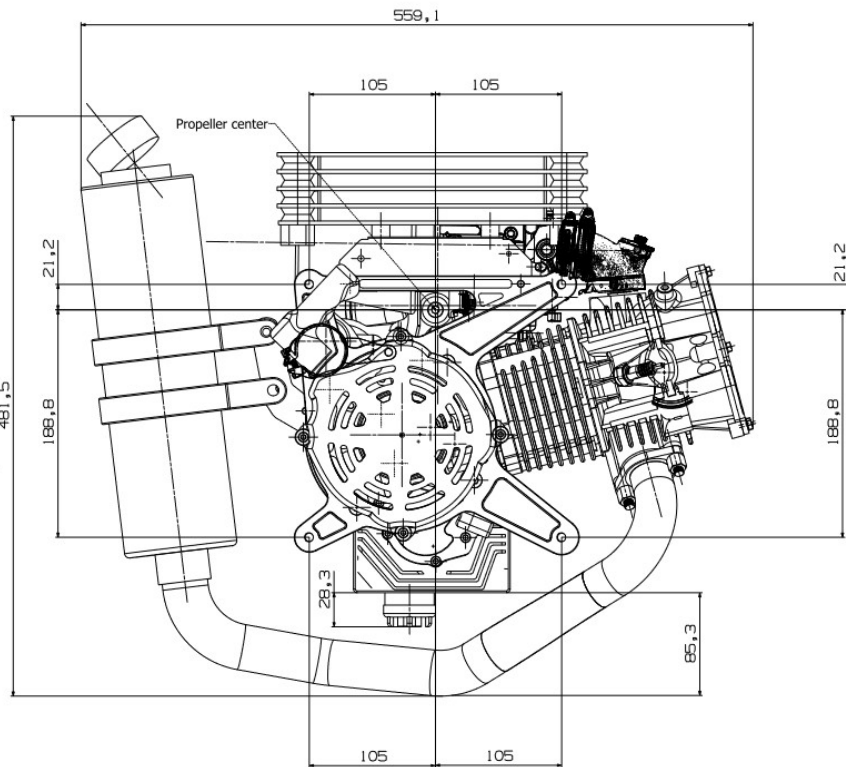
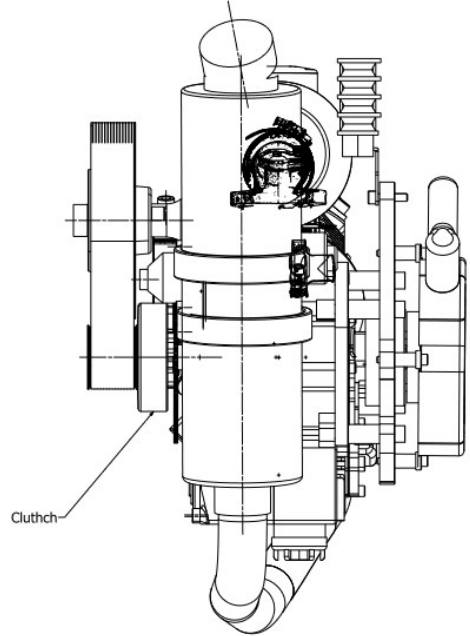
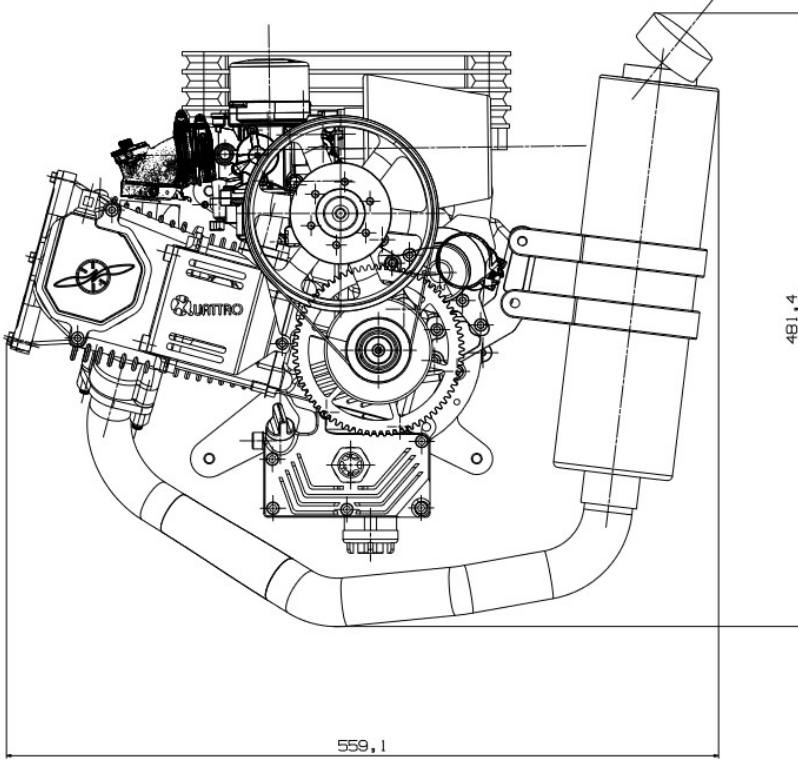

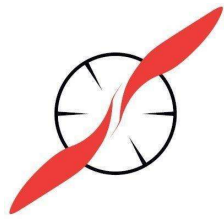

EOS
— ENGINE —

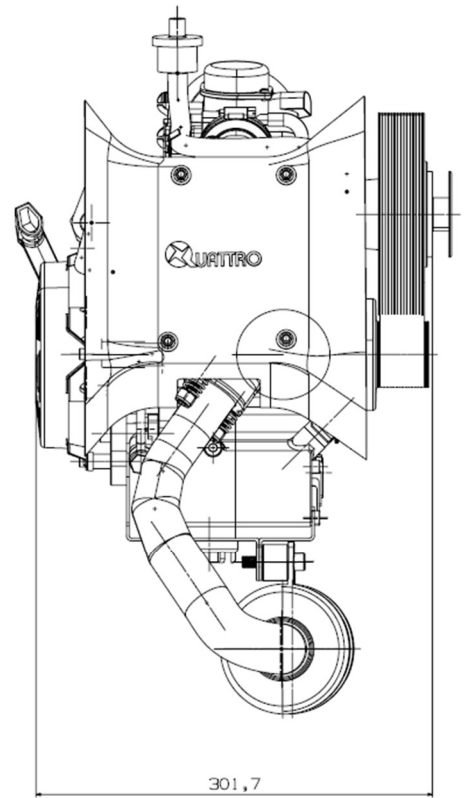
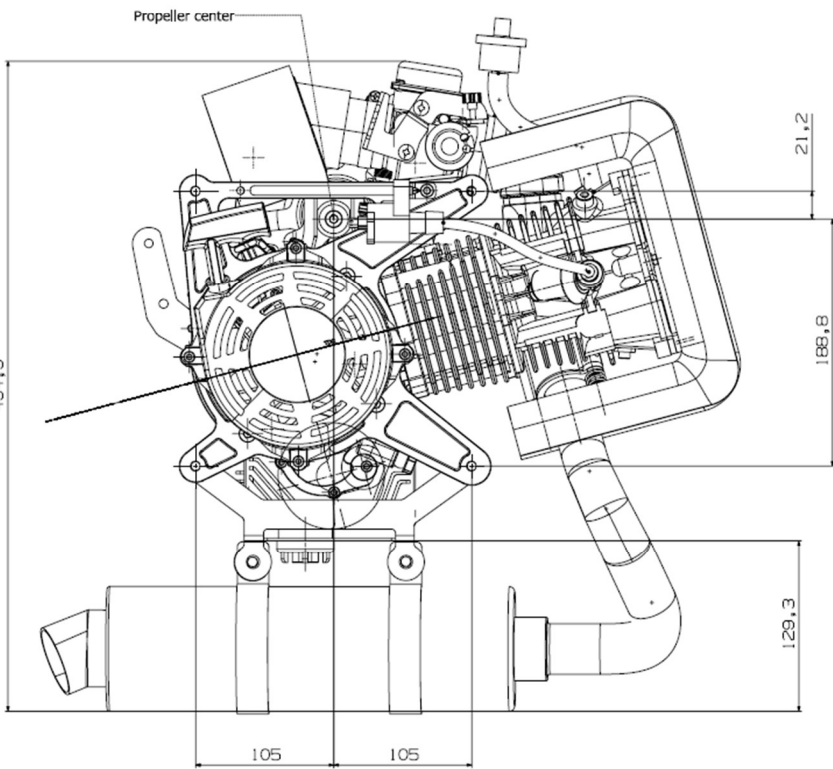
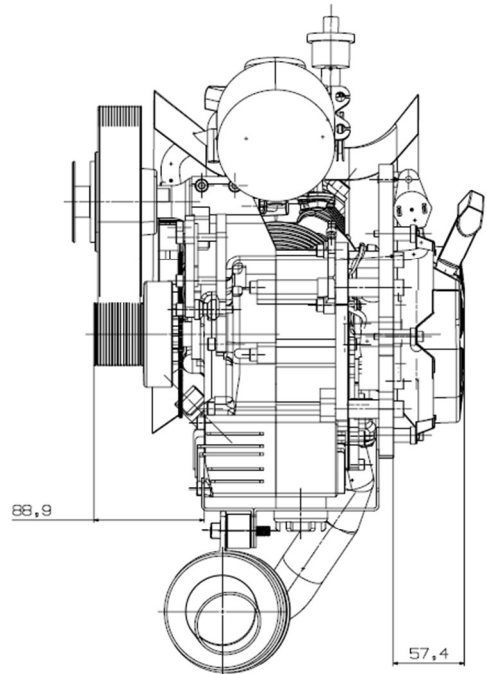
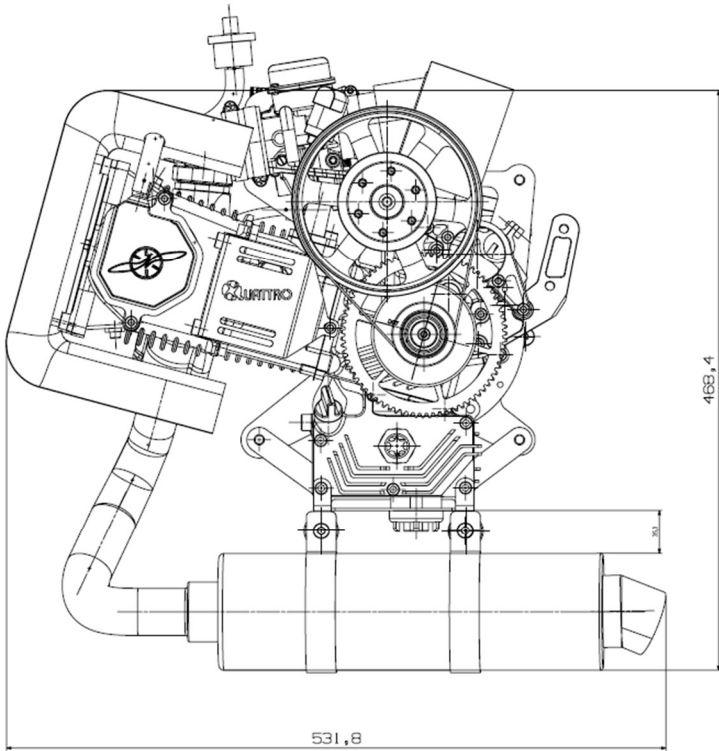

Electrical System

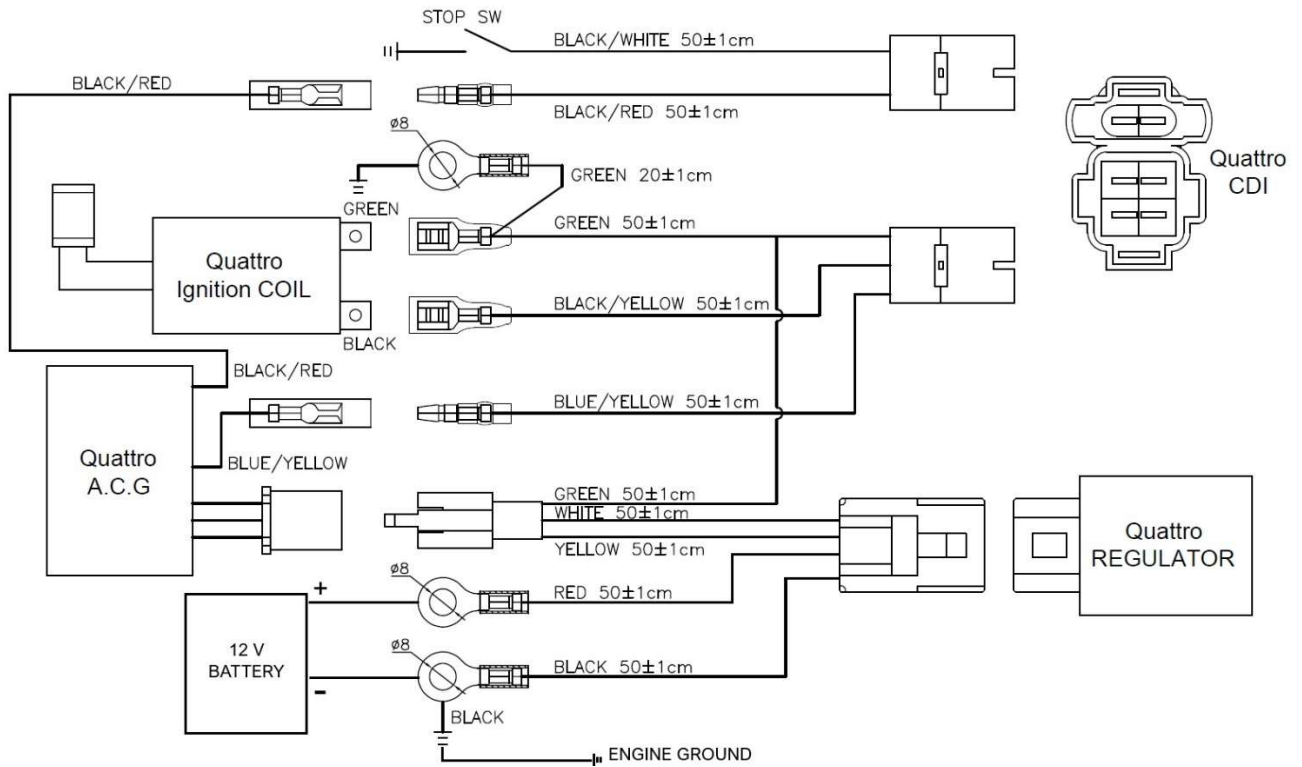

Important: The rectifier is only required when charging a lead battery. You also need a direct connection from battery ground to engine ground!

Starter Wiring Diagram

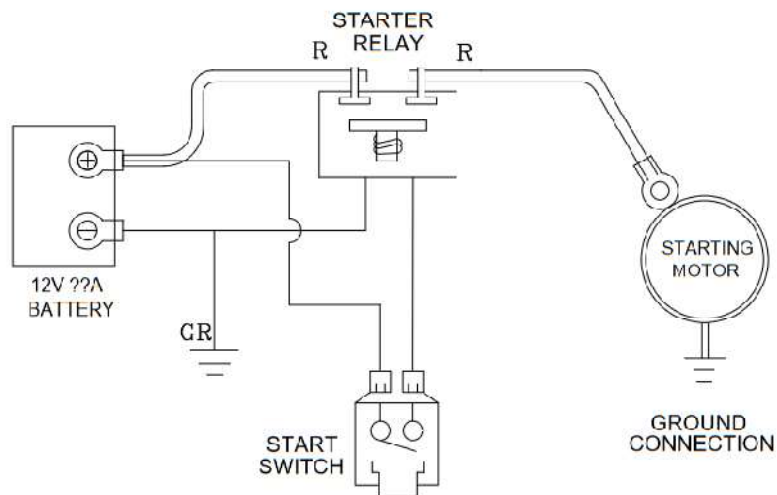

Quattro Electric Start System Diagram

Two-pin electric start relay

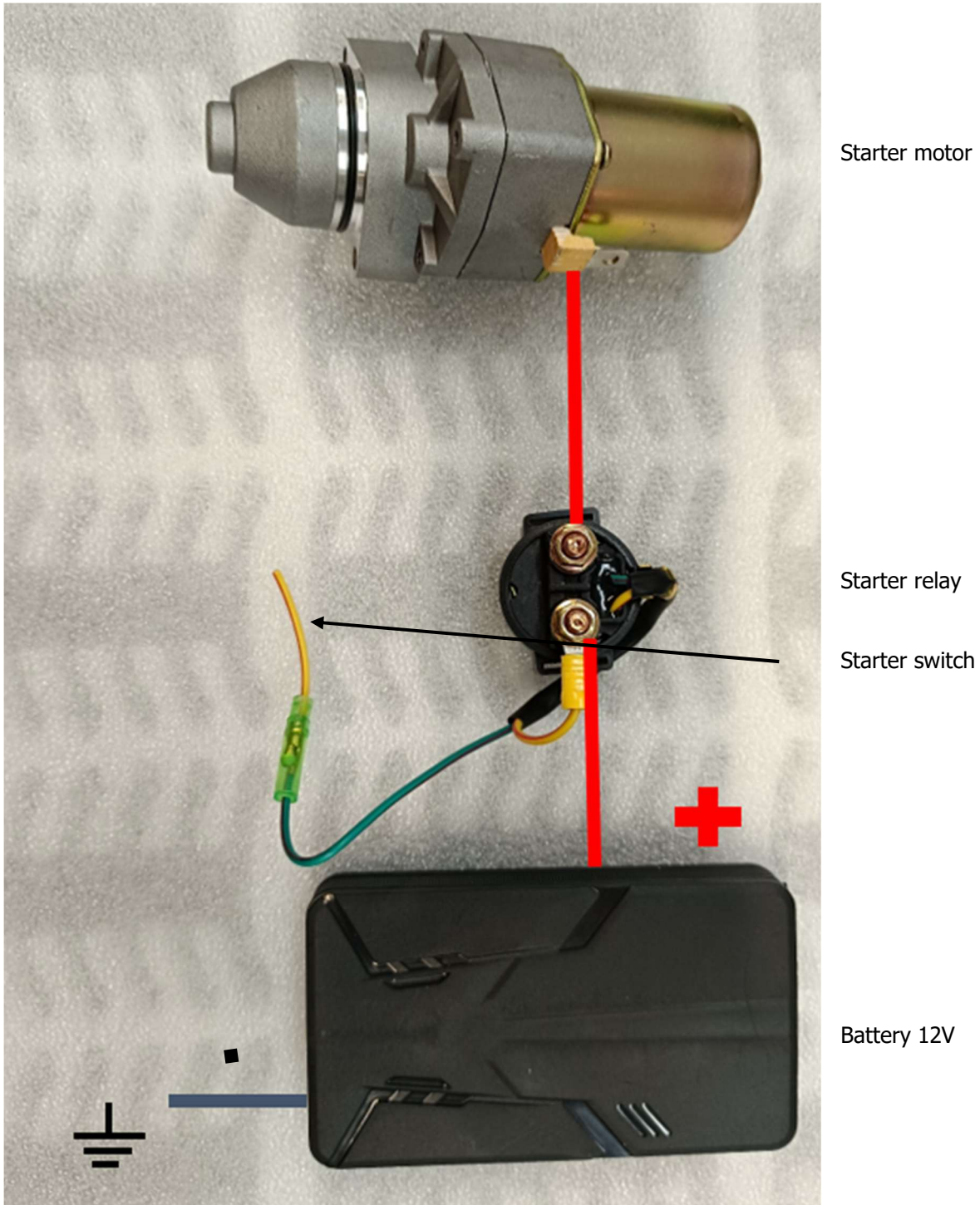

Connect starter switch and battery ground (-) to ground point on the engine – use 6mm² cable!
The starter motor ground cable must be connected directly to the battery.

Engine Grounding Point



IMPORTANT!

Please connect all ground wirings to the engine ground contact point. The green wire is for ignition. If the green ground wire is not connected to this point, the engine will not start correctly and can cause wrong ignition timing. We recommend using a min 6mm² starter cable! Best option is 8mm².

Wiring installation

If no battery is used, the installation of the rectifier is not required. The wiring harness is delivered as shown in Figure 10a – to the left of the white connector is the voltage rectifier. To the right of the white connector is the wiring for the ignition system. If you plan on not charging the battery, you should remove the white wire from the connector and discard the charging system wiring and rectifier.



Fig 10a. Wiring Harness for battery charging

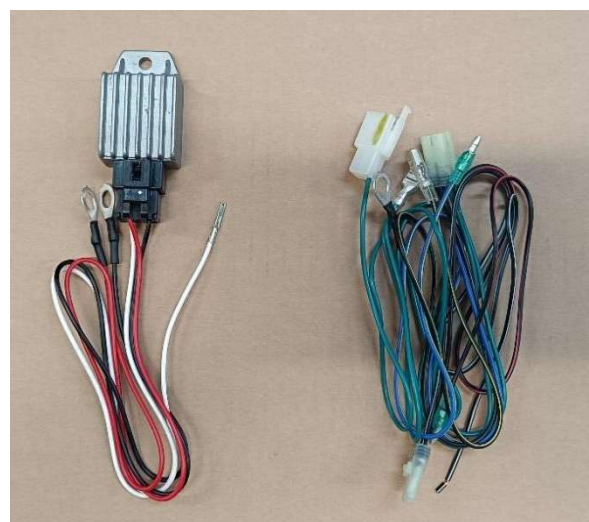

Fig 10b. Wiring Harness without battery charging

Fuel Supply System

Important note!

The EOS QUATTRO ENGINE operates utilizing a vacuum-driven membrane fuel pump for efficient fuel supply.

****WARNING:**** The EOS QUATTRO is specifically engineered to function exclusively with the provided fuel system. Its distinctive bypass system ensures optimal fuel flow and pressure.

****NOTE:**** It is imperative to inspect the bypass reduction (alloy reduction, indicated by a red circle) every 100 hours. The bypass channel must remain clean and free of cracks. A clogged bypass channel may lead to carburetor overflow. Additionally, the vacuum hose should not exceed a length of 250mm, measured from the carburetor to the fuel pump (refer to the accompanying image).

****WARNING:**** ONLY utilize the fuel pump supplied by EOS. This fuel pump features a unique bypass system that guarantees the correct fuel flow and pressure. The use of alternative fuel pumps is strictly prohibited.

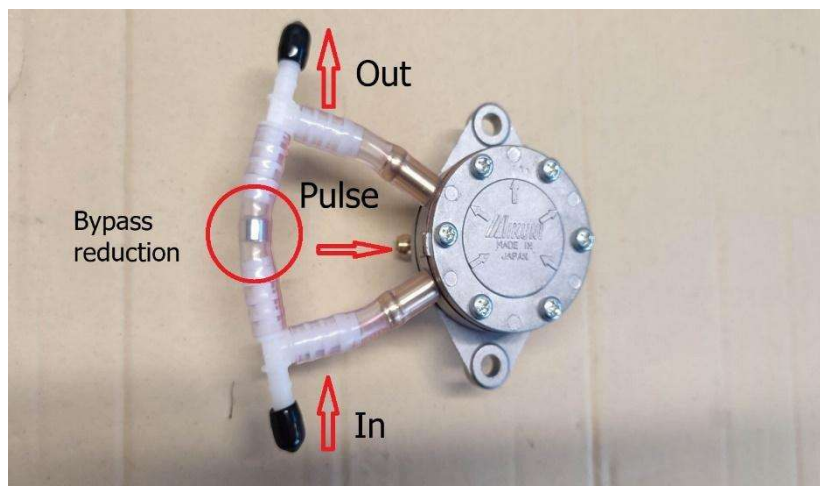



Installation Notes

The Black/White cable connected to the CDI completes the circuit to the kill switch. This connection allows the pilot to halt the engine effectively. The EOS QUATTRO ENGINE is equipped with an additional wiring harness specifically designed for the voltage regulator.

The carburetor features a vent tube affixed to the bowl and a return pipe that must be properly installed to the fuel tank. It is essential that the routing of this return pipe is arranged to ensure a consistent downward slope towards the fuel tank, eliminating any potential for fuel accumulation within the line. Any modifications to the fuel breather and return lines may result in fuel supply issues. The fuel return line can be routed in conjunction with the fuel tank vent line. It is important to note that the carburetor mixture is pre-set at the factory; utilizing a different jet than the one provided by the manufacturer will void the warranty.

Engine Ventilation:

The engine is equipped with a breather hose (black hose) and a PCV valve to mitigate crankcase pressure. The breather hose connects to the engine ventilation cover outlet. A tube can be attached to the PCV valve located at the top of the black hose to direct air away from the engine.

New version model 2025: The vent hose should be installed as high as possible to prevent oil leakage – see picture

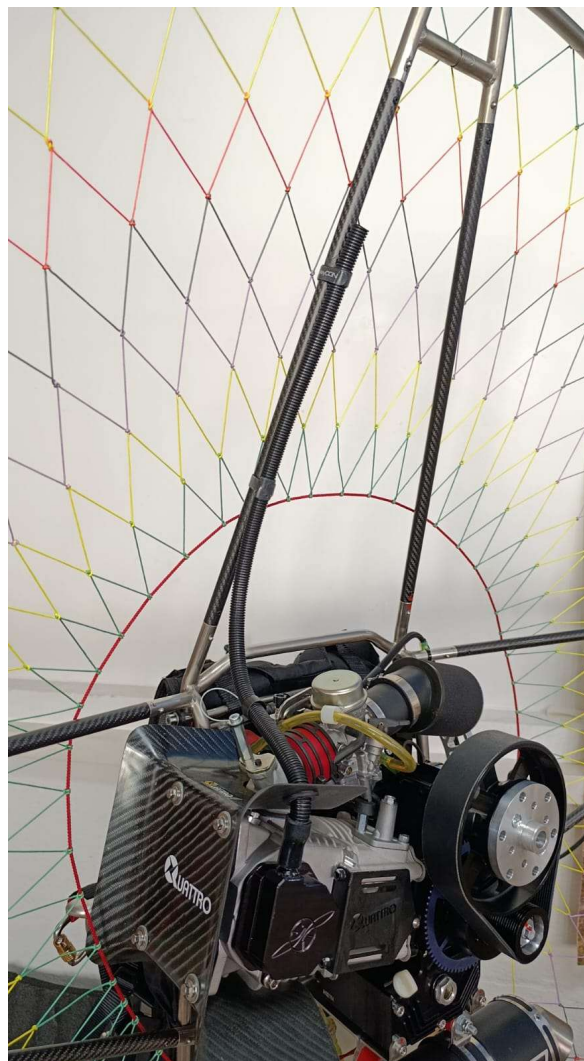



Engine angle:

The maximum technical angle in flight is 15 degrees. Please ensure that your system is installed and adjusted correctly. If the angle is tilted too far backwards, oil can be expelled through the engine ventilation. It's not only about the angle at which the engine operates properly – for optimal propeller performance, the ideal angle is 0 degrees, as any deviation from the flight direction reduces propeller efficiency.

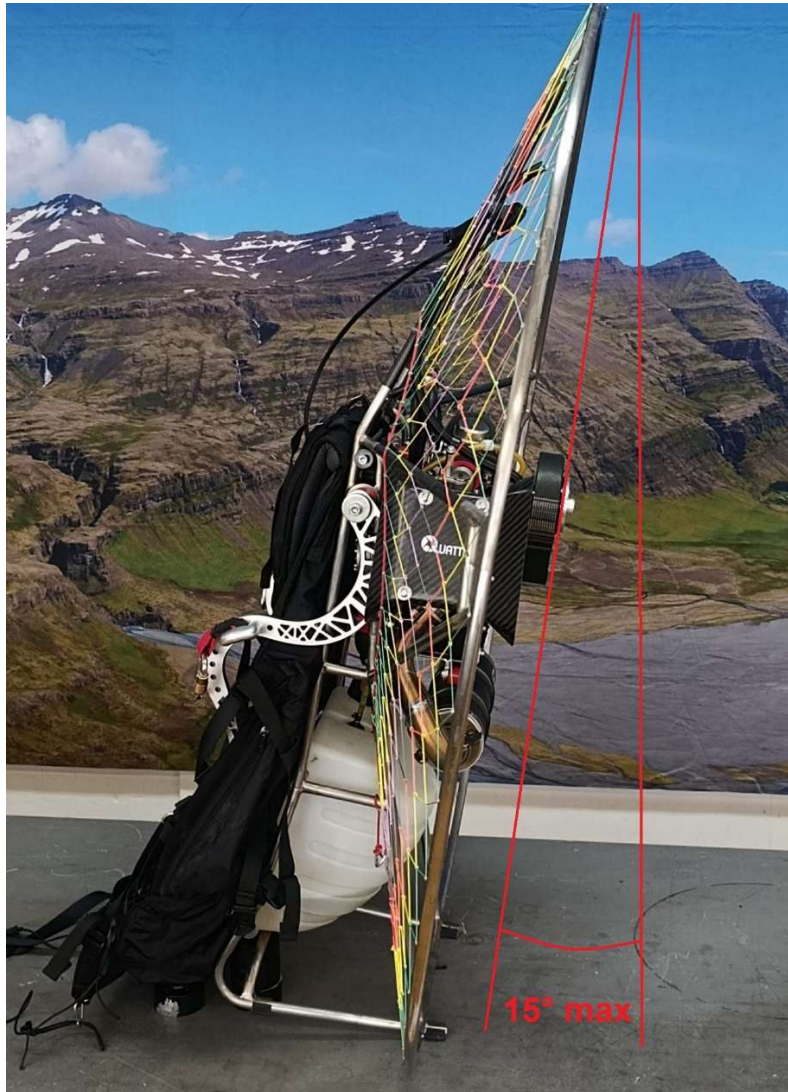

Fuel Line Attachment:

A primer bulb should be installed on the fuel supply line between the tank and the vacuum fuel pump. It is imperative that fuel lines maintain a 6mm inner diameter.



Choke:

The CVK carburetor is equipped with a choke. Typically, utilizing the choke to initiate engine start is unnecessary. However, when the EOS QUATTRO ENGINE is cold, it is advisable to open the choke, prime the engine using the accelerator pump by quickly pressing and releasing the throttle 5-7 times, and then start the engine. Please refrain from holding down the throttle while pressing the starter button.

Once the engine has been running for 30 seconds, close the choke.

WARNING: Engaging the choke will cause the propeller to begin spinning!

Throttle Cable:

EOS QUATTRO ENGINES do not come with a throttle assembly. Throttles must be purchased separately. After installation, ensure that the carburetor lever can fully open and close. The engine kill button on the throttle should be easily accessible during takeoff and while in flight. Avoid over-tightening the throttle cable; a slight slack is necessary.

Oil Cooling:

Maintain cleanliness of the oil cooler at all times.

Attention: The oil cooler will become extremely hot after engine operation! Ensure there is adequate clearance around the oil cooler to facilitate airflow. A minimum distance of 100mm between the harness and the oil cooler is required.

Cooling Shroud:

For optimal engine cooling efficiency, it is recommended to utilize the HELIX QUATTRO Propeller. This will ensure sufficient airflow through the cylinder head while the propeller is in motion.

Exhaust:

Always maintain a minimum distance of 100mm between the exhaust system and your frame or fuel tank, as the manifold can reach very high temperatures.

WARNING: Do not remove the DB killer cap from the muffler/silencer outlet, as this will lean the mixture and potentially damage your engine.

Installation Cooling shroud

- 1) Use blue Loctite
- 2) Tighten the screws with 9nm



Propeller

EOS ENGINE and Helix Carbon GmbH/Germany have developed a propeller for the EOS QUATTRO. We recommend using only this propeller.

It guarantees maximum performance of the engine and maximum thrust across the entire RPM range. Additionally, it is optimized to provide the best cooling for the engine. To use this propeller, the appropriate propeller adapter is required.

You can obtain this propeller exclusively from EOS Engines.



The use of another propeller will void the manufacturer's warranty and further damage to the engine cannot be ruled out.

Adjustments - Carburetor Idle Speed

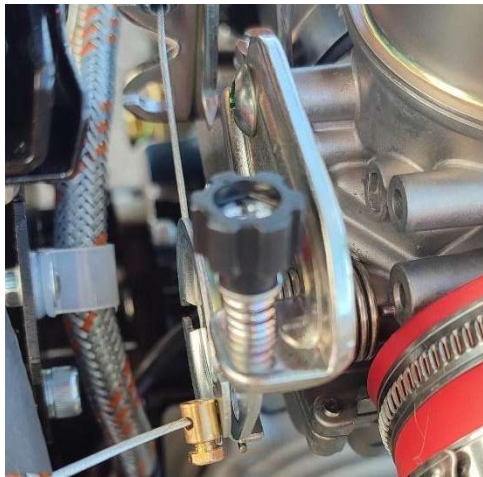

Fig 14a



Fig 14b

The Idle speed is adjusted by turning the small screw at the side of the throttle quadrant as shown in Figure 14a.

The idle speed should be:

1900- 2100 RPM with the clutch – 2000 RPM version,
2100 to 2300 RPM with the clutch – 2800 RPM version.

The black hose attached to the float chamber shown on figure 14b is the carburetor overflow and drain line. This must be connected to the fuel tank so fuel can drain back into the tank.

Adjustments - Exhaust Spring Tension



The engine exhaust is secured with two M8-bolt fasteners at the cylinder, facilitating the expansion and contraction of the manifold. The springs are factory pre-set to ensure optimal flexibility of the manifold. Should you need to adjust the spring tension, it is recommended to maintain a gap of 0.4 to 0.6 mm between each coil of the spring, as illustrated in the accompanying image.



Pre-Start Checks - Warnings

Engine Oil Level

Ensure that the engine is positioned on a level surface. The oil level must be maintained between the halfway (minimum) and top (maximum) marks of the glass oil window. If an oil cooler is installed, start the engine and let it run for 30 seconds. Then switch it off and check the oil level as described above.

Fuel System

Verify that there is an adequate amount of fuel for the intended flight.

Exhaust System

Confirm that the exhaust system is securely attached. Inspect the swivel springs at both ends of the manifold and assess the condition of the silencer clamps. ****Caution:**** Do not open the M8 copper nuts, as these are factory pre-set to ensure optimal clamping force, allowing for sufficient expansion and contraction of the exhaust assembly. There should be a gap of 0.4 to 0.8 mm between each coil of the springs (refer to page 8 for details).

Air Filter and Carburetor

Ensure that the air filter is clean and undamaged. Confirm that the filter is securely tightened. Inspect the securing clamps to ensure they are fastened properly. Additionally, check the condition of the rubber duct located between the carburetor and the inlet manifold, ensuring that both clamps are tight and correctly positioned.

Spark Plug Cable and Cap

Verify that the spark plug cap is fully engaged and securely seated onto the plug. It is unnecessary to remove or check the spark plug before each flight, as repeated removal of the spark plug cap may lead to it becoming loose.

Oil Cooler

Ensure that the oil cooler is free from debris to facilitate unobstructed airflow. Additionally, check for any signs of leakage.

Throttle Assembly

Conduct a visual inspection to confirm full throttle travel on the carburetor, ensuring that the throttle opens and closes completely and smoothly.

Reduction Drive and Propeller

Inspect the propeller for any cracks or chips. Ensure that the mounting bolts are tightened to a torque of 8 Nm.

Drive Belt

Examine the Poly-V drive belt for any signs of cracks, wear, and proper tension.



Propellers pose significant safety risks. It is imperative to refrain from starting the engine in any situation where there is a possibility of the propeller making contact with the operator, any other individuals, or surrounding objects.

Operation Notes



Before starting your engine, it is essential to adhere to the comprehensive pre-start checklist outlined on page 16.

Ensure the propeller cannot contact anything or anyone else. In the case of a paramotor, the machine must either be either securely strapped to a pilot or securely fixed to proprietary test platform.

DO NOT start your paramotor unless one of these 2 rules are obeyed.



Breaking-In

All Engines undergo comprehensive testing prior to customer release. To prevent any potential damage to your engine during the initial critical running hours, it is imperative to follow the outlined procedures.

After the first three hours of operation, it is essential to change the oil and clean the oil filter. At the ten-hour mark, you are required to change the oil again, clean the oil filter, and verify the engine valve clearance. Detailed instructions for this procedure can be found in the "Service Schedule" in this manual. Following the ten-hour service, please adhere to the regular maintenance schedule.

Post break-in period (first ten hours), the engine is capable of utilizing full power for take-off (maximum duration of one minute). Once airborne, it is advisable to reduce power to 7000 RPM or lower. It is recommended to vary the engine RPM during this phase. Please note that starting the engine on the ground is strongly discouraged.

Starting

Use the manual choke on the CVK carburetor to start your cold EOS QUATTRO ENGINE. The accelerator pump can also be used instead by pushing the throttle mechanism 4-6 times.

Please pay attention when you open your choke, the engine RPM will be higher at choke operation and the propeller will be spinning!

Don't press the throttle with the engine off if you don't intend to start the engine— this will cause the accelerator pump to spray fuel into the carburetor and will cause the engine to flood.

Starting – Cold Start: Below 0C/32F

1. Ensure the carburetor is full of fuel by squeezing the primer bulb.
2. Make sure that the throttle is fully closed.
3. Open the choke or pump the throttle 5-7 times, temperature dependent.
4. Keep the throttle released.
5. Use electric or pull starter to start the engine.
6. Keep the engine in the fast idle for 30 – 60 seconds.
7. Kill the motor to check the kill button.

If the ambient temperature is too cold, you will need to continue by opening the choke and pumping the throttle 3 times.

Starting – Hot Start:

1. Keep the throttle on idle or slightly open approx. 5%
2. Use the electric starter or the pull starter to start the engine.

If the engine doesn't start using the electric starter within 10 seconds – stop and retry after doing another pre-start-check. If you use the electric starter for more than 10 seconds you may damage starter motor or starter gear.



Service Schedule

To ensure optimal performance of your engine, it is essential to adhere to the prescribed service schedule. Neglecting to perform the necessary maintenance at the recommended intervals may lead to diminished performance or other significant issues that could impact your warranty.

FREQUENCY	ACTION	Date, Signature
Before flight and after each use	Check oil level	
	Visually check fuel connections and oil connections	
	Check fixing and rubber mounts	
	Check that throttle returns to fully closed position and full throttle can be obtained, do not push the throttle to often! The engine will be flooded	
	Check propeller leading edge for damage	
	Check all securing nuts/bolt/engine mounts	
After initial (3hours) 10 hours	Replace engine oil & clean oil filter	
	Check valve clearance and oil hose screws torque	
Every 25 hours	Replace engine oil & clean oil filter	
	Check drive belt tension & wear	
	Check valve clearance	
Every 50 hours	Replace air filter and spark plug. Use EOS QUATTRO ENGINE filter!!	
	Grease exhaust connection with copper grease	
Every 100 hours or every year	Replace engine ventilation valve	
	Replace engine mounts, exhaust mounts & oil cooler mounts, replace intake connection rubber	
	Replace drive belt	
	Replace fuel filter	
Every 150 hours	Replace silencer sound-absorbing-wool	
Every 500 hours	Contact your local EOS Service Center regarding 'Zero Hour' overhaul or time extension	

Storage Instructions

If you plan not to use your engine for an extended period of time (3+ months) follow the steps below prior to storing your engine:

1. Loosen drive belt
2. Remove and drain fuel tank
3. Drain carburetor float bowl - Using the drain screw squeeze primer bulb and evacuate all the
4. fuel from the system and then re-tighten screws, otherwise let your EOS Quattro engine run at
5. idle speed until the engine comes to a stop.

Returning EOS QUATTRO ENGINE to service after longer storage period:

1. Change the engine oil and clean the oil filter.
2. Refuel.
3. Re-tension drive belt and check wear.
4. Thoroughly follow pre-flight checks prior to starting your engine.

Maintenance Procedures
Oil & Filter Change

Please note that your engine must be up to normal operating temperature before draining oil.

1. The engine should be in an upright position when changing the oil.
2. Remove the oil drain plug with a 17mm socket and remove the oil filter.
3. Drain all used oil into a suitable container.
4. Clean the oil filter using a carburetor or a brake cleaner.
5. First, reinstall the filter and the spring.
6. Next, install the oil drain plug.
7. Tighten oil drain plug with a 17mm socket (do not overtighten). Recommended torque is 35 Nm.
8. Carefully fill with fully synthetic 4 stroke motorcycle oil (see Page 2 for recommended oil types) until the oil reaches the middle of the oil level window.
9. Run the engine then recheck oil level and fill up as necessary.

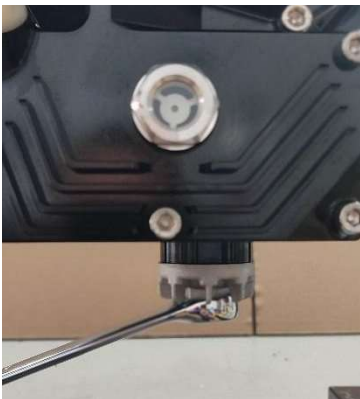

7)

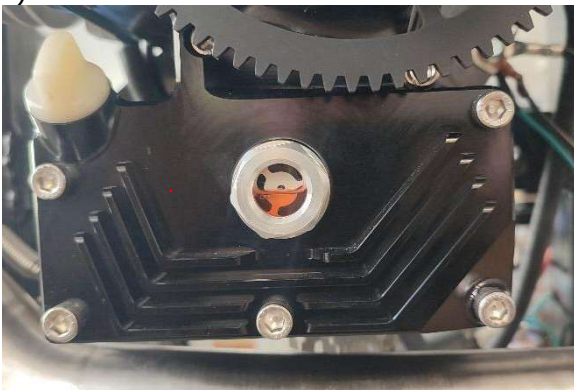

Ensure that the oil filter and the spring fit correctly. Installing the filter incorrectly will result in severe engine damage.

Drive Belt Tensioning

The optimal tension of the drive belt is essential to prevent slippage. It is normal to experience slight slipping, accompanied by a chirping noise, at idle speed when the engine is equipped with a direct drive system. We recommend maintaining a belt deflection of 4-6mm, as illustrated in the accompanying image.

The belt will be pre-tensioned at the factory; however, it is crucial to verify the tension during the 3-hour service interval. Additionally, the drive belt adjustment should be inspected prior to each flight.

To adjust the drive belt, loosen the two M6 bolts located at the top of the reduction pylon, as well as the M8 bolt on the backside. Utilize a 23 mm wrench to turn the eccentric drive belt adjuster: clockwise rotation will tighten the belt, while counter-clockwise rotation will loosen it. After making the necessary adjustments, re-tighten the bolts (M6 to 12 Nm, M8 to 17 Nm) and verify the belt deflection.

Caution: Avoid over-tightening the belt, as this may lead to bearing failure and a reduction in available thrust.

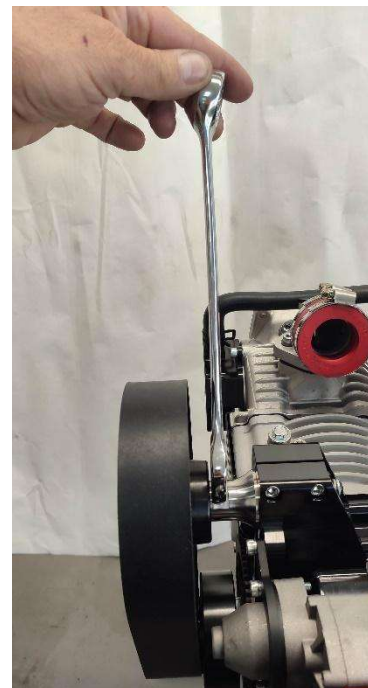
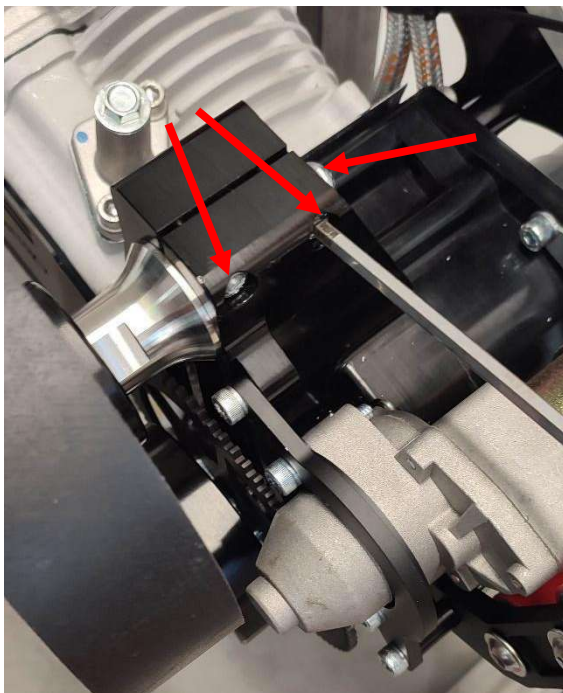

Valve Clearance Adjustment

Remove the valve cover and the adjustment cover. Rotate the engine until inlet valve (nearest the top of the engine) is fully closed and the cam lobe is 180° from the cam follower. Using a suitable feeler gauge, inserted between the valve top and the cam follower adjusting screw. Check and/or adjust by loosening the 8 mm lock nut (see specifications on page 4 for valve clearances).

The same procedure is used on the exhaust valve (nearest the exhaust). However, be aware of the easy start actuator positioned on the exhaust cam base circle. Make sure the cam follower is clear of this to get a correct measurement.

After adjustment ensure both lock nuts are tightened (6nm) and re-fit cam cover (M6 12nm) and adjustment cover.

Remove any excess oil from the cylinder head.



Starter Motor Sprocket Adjustment

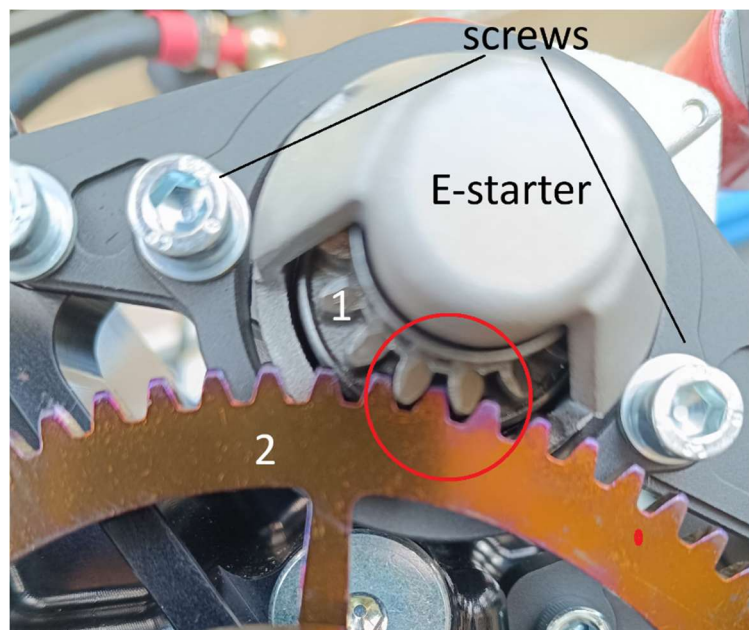

To adjust the starter motor correctly in relation to the starter sprocket (2), loosen the screws to allow for vertical movement. For secure fixation, it is recommended to use blue Loctite and tighten to a torque of 16 Nm.

The gear play (distance) between the starter motor gear (1) and the starter sprocket gear (2) should be maintained between 0.2 mm and 0.3 mm, as indicated by the red circle.



Screw Torque Specifications

Screw	Dimension	Torque	Loctite blue
Cylinderhead cam-cover with oil cooler	M 6	12 nm	no
Cylinderhead cam-cover with cooling shroud	M 6	9 nm	yes
Cylinderhead nut	M 8	24 nm	no
Ventilaton cover	M 6	14 nm	yes
Intake manifold	M 6	14 nm	no
Clutch fix screw	M 6	17 nm	yes
Propeller shaft	M 8	17 nm	yes
	M 6	12 nm	yes
E-Starter	M 6	16 nm	yes
Flywheel	M 14	40 nm	yes
Oil cooler bracket	M 6	14 nm	yes
Exhaust support	M 6	16 nm	yes
Oil pump cover	M 4	7 nm	no
	M 5	10 nm	no
Oil hose screw	M 10	25 nm	yes
	M 12	30 nm	yes
Crankcase screws	M 6	14 nm	no
Engine support	M 8	25 nm	yes

Warranty

The EOS QUATTRO ENGINE is backed by a 12-month limited parts warranty covering all engine components for the original purchaser. All warranty claims must be processed through EOS ENGINE by R-moto GmbH, Austria, and are subject to return-to-base conditions. EOS ENGINE disclaims any responsibility for delivery or freight charges, including customs duties or taxes. A comprehensive service history must be maintained and provided to validate the warranty.

Warranty claims will be deemed invalid under the following circumstances:

- The engine has not been installed by qualified aircraft personnel.
- Damage resulting from immersion in water or improper usage.
- Damage due to failure to perform proper pre-flight checks.
- Damage arising from neglecting the prescribed service schedule.
- Damage caused by physical impacts, such as dropping or falling, affecting the paramotor or engine.
- Damage incurred from starting the engine without a properly fitted propeller.
- Damage resulting from the use of an incorrect propeller type.
- Damage due to improper adjustment of drive belt tension.
- Damage from incorrect valve clearance adjustments.
- Damage caused by the use of incorrect fuel or oil types or grades, or due to insufficient engine oil or incorrect fluid levels.
- Damage resulting from the removal of the DB Killer.
- Use of any propeller other than the original EOS QUATTRO propeller as specified by EOS Engine/Helix.

Any modifications to the engine design without prior written consent from EOS QUATTRO ENGINE will void the manufacturer's warranty.



Disclaimer

DANGER

Engine failure may necessitate emergency landings, which can result in serious bodily injury or death.

It is imperative that aircraft equipped with this engine are not operated in locations, airspeeds, altitudes, or under circumstances that preclude a successful no-power landing. Such aircraft should only be flown under appropriate Visual Flight Rules (VFR) conditions.

Paramotors, trikes, and small ultralight aircraft are not certified or licensed as aircraft. It is the responsibility of the owner/pilot to operate their engine in compliance with the rules and regulations established by the governing authority in their respective country or territory. EOS ENGINE by R-moto GmbH, Austria, disclaims any liability for damages or fatalities resulting from the misuse of any product manufactured or utilized by them.

WARNING: This is not a certified aircraft engine. It has not undergone any safety or durability testing and does not conform to any aircraft standards. It is intended solely for use in experimental, uncertified aircraft and vehicles where an engine failure will not compromise safety. The user assumes all risks associated with its use and acknowledges the potential for sudden engine failures.

This manual serves as operational guidance for the EOS QUATTRO ENGINE exclusively. The use of this engine is entirely at the user's own risk; do not operate if you are aware of any issues with your equipment, personal health, weather conditions, or any other adverse circumstances.

No part of this manual may be reproduced or distributed in any form or by any means without the prior written consent of EOS ENGINE by R-moto GmbH, Austria.

